

ALTO SHAAM®

Heated Display Cases

Full Service or Self Service



ED2SYS-48

ED2-48



ED2SYS-72

ED2-72



ED2SYS-96

ED2-96



Models:

ED2-48; ED2SYS-48
ED2-48/P; ED2SYS-48/P

EU2SYS-48; EU2SYS-48/P

ED2-72; ED2SYS-72
ED2-72/P; ED2SYS-72/P
ED2-72/PL; ED2SYS-72/PL
ED2-72/PR; ED2SYS-72/PR

EU2SYS-72; EU2SYS-72/P
EU2SYS-72/PL
EU2SYS-72/PR

ED2-96; ED2SYS-96
ED2-96/PL; ED2SYS-96/PL
ED2-96/PR; ED2SYS-96/PR

EU2SYS-96; EU2SYS-96/P
EU2SYS-96/PL
EU2SYS-96/PR

• **INSTALLATION**

• **OPERATION**

• **MAINTENANCE**

HALO
HEAT.

24•7
Your Service Hotline
1-800-558-8744

W164 N9221 Water Street • P.O. Box 450 • Menomonee Falls, Wisconsin 53052-0450 USA

PHONE: 262.251.3800 • 800.558.8744 USA/CANADA

FAX: 262.251.7067 • 800.329.8744 U.S.A. ONLY

www.alto-shaam.com

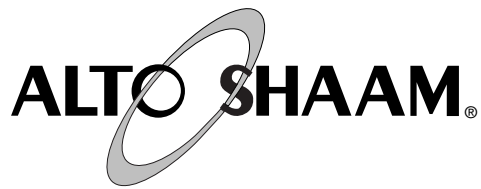

DELIVERY

This Alto-Shaam appliance has been thoroughly tested and inspected to insure only the highest quality unit is provided. Upon receipt, check for any possible shipping damage and report it at once to the delivering carrier. *See Transportation Damage and Claims section located in this manual.*

This appliance, complete with unattached items and accessories, may have been delivered in one or more packages. Check to ensure that all standard items and options have been received with each model as ordered.

Save all the information and instructions packed with the appliance. Complete and return the warranty card to the factory as soon as possible to assure prompt service in the event of a warranty parts and labor claim.

This manual must be read and understood by all people using or installing the equipment model. Contact the Alto-Shaam service department if you have any questions concerning installation, operation, or maintenance.

NOTE: All claims for warranty must include the full model number and serial number of the unit.

UNPACKING

1. Carefully remove the appliance from the carton or crate.

NOTE: Do not discard the carton and other packaging material until you have inspected the unit for hidden damage and tested it for proper operation.

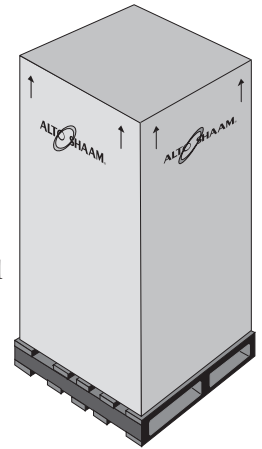

2. Read all instructions in this manual carefully before initiating the installation of this appliance.

DO NOT DISCARD THIS MANUAL.

This manual is considered to be part of the appliance and is to be provided to the owner or manager of the business or to the person responsible for training operators. *Additional manuals are available from the Alto-Shaam service department.*

3. Remove all protective plastic film, packaging materials, and accessories from the appliance before connecting electrical power. Store any accessories in a convenient place for future use.

SAFETY PROCEDURES AND PRECAUTIONS

Knowledge of proper procedures is essential to the safe operation of electrically and/or gas energized equipment. In accordance with generally accepted product safety labeling guidelines for potential hazards, the following signal words and symbols may be used throughout this manual.

DANGER



Used to indicate the presence of a hazard that **WILL** cause severe personal injury, death, or substantial property damage if the warning included with this symbol is ignored.

WARNING



Used to indicate the presence of a hazard that **CAN** cause personal injury, possible death, or major property damage if the warning included with this symbol is ignored.

CAUTION



Used to indicate the presence of a hazard that can or will cause minor or moderate personal injury or property damage if the warning included with this symbol is ignored.

CAUTION

Used to indicate the presence of a hazard that can or will cause minor personal injury, property damage, or a potential unsafe practice if the warning included with this symbol is ignored.

NOTE: Used to notify personnel of installation, operation, or maintenance information that is important but not hazard related.

1. This appliance is intended to hold or process foods for the purpose of human consumption. No other use for this appliance is authorized or recommended.
2. This appliance is intended for use in commercial establishments where all operators are familiar with the purpose, limitations, and associated hazards of this appliance. Operating instructions and warnings must be read and understood by all operators and users.
3. Any troubleshooting guides, component views, and parts lists included in this manual are for general reference only and are intended for use by qualified technical personnel.
4. This manual should be considered a permanent part of this appliance. This manual and all supplied instructions, diagrams, schematics, parts lists, notices, and labels must remain with the appliance if the item is sold or moved to another location.

NOTE



For equipment delivered for use in any location regulated by the following directive:

DO NOT DISPOSE OF ELECTRICAL OR ELECTRONIC EQUIPMENT WITH OTHER MUNICIPAL WASTE.

INSTALLATION

DANGER



IMPROPER INSTALLATION, ALTERATION, ADJUSTMENT, SERVICE, OR MAINTENANCE COULD RESULT IN SEVERE INJURY, DEATH OR CAUSE PROPERTY DAMAGE.

READ THE INSTALLATION, OPERATING AND MAINTENANCE INSTRUCTIONS THOROUGHLY BEFORE INSTALLING OR SERVICING THIS EQUIPMENT.

CAUTION



METAL PARTS OF THIS EQUIPMENT BECOME EXTREMELY HOT WHEN IN OPERATION. TO AVOID BURNS, ALWAYS USE HAND PROTECTION WHEN OPERATING THIS APPLIANCE.

CAUTION



TO PREVENT PERSONAL INJURY, USE CAUTION WHEN MOVING OR LEVELING THIS APPLIANCE.

SITE INSTALLATION

In order to maintain established National Sanitation Foundation standards, all stationary floor models must be sealed to the floor with a R.T.V. or silastic meeting N.S.F. requirements or have 6" (152mm) unobstructed clearance beneath the unit.

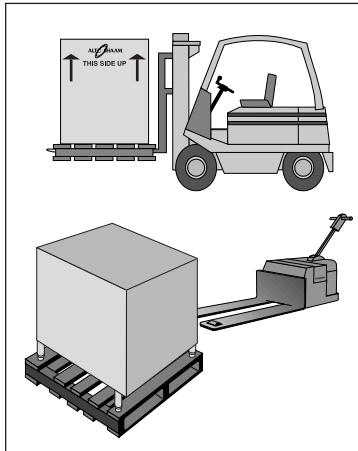

1. The appliance must be installed on a stable and level surface.
2. **DO NOT** install this appliance in any area where it may be affected by any adverse conditions such as steam, grease, dripping water, high temperatures, or any other severely adverse conditions.
3. **DO NOT** install a heated display case near a cold air source such as a freezer, air conditioning vents, or in any area where outside air fluctuation can affect performance.
4. This appliance must be kept free and clear of any obstructions blocking access for maintenance or service.

MINIMUM CLEARANCE REQUIREMENTS

Counter and table units must be mounted on legs of a sufficient 4" (102mm) height to provide minimum unobstructed space beneath the unit. These legs are supplied with the unit. Warranty will become null and void if these directions are not followed.

A number of adjustments are associated with initial installation and start-up. It is important that these adjustments be conducted by a qualified service technician. Installation and start-up adjustments are the responsibility of the dealer or user. These adjustments include but are not limited to thermostat calibration, door adjustment, leveling, electrical hook-up and installation of optional casters or legs.

LEVELING

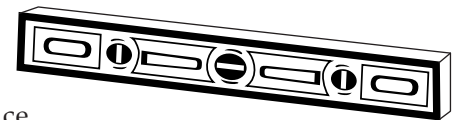

Level the appliance from side-to-side and front-to-back with the use of a spirit level.

We recommend checking the level periodically to make certain the floor has not shifted nor the appliance moved.

NOTE: Failure to properly level this appliance can cause improper function.

INSTALLATION

SITE INSTALLATION

ED2 & ED2SYS SERIES

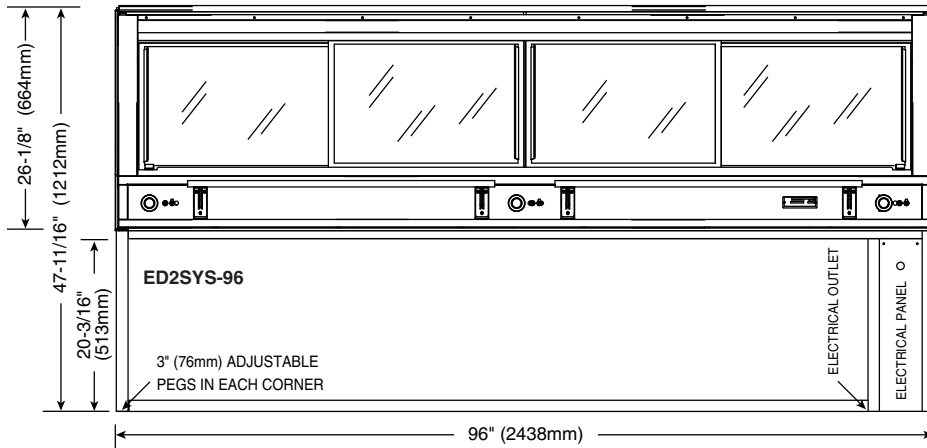
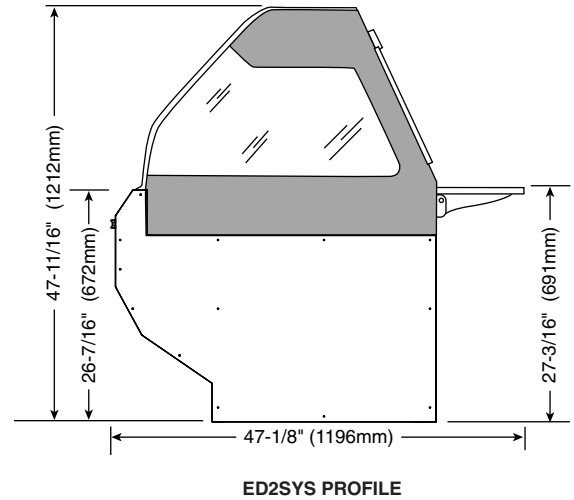
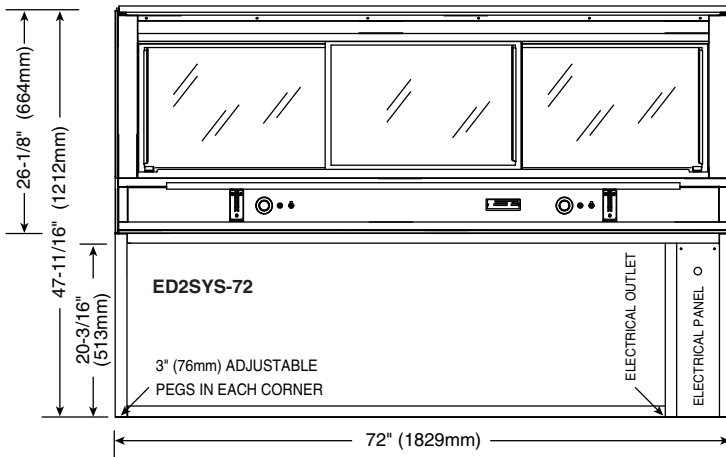
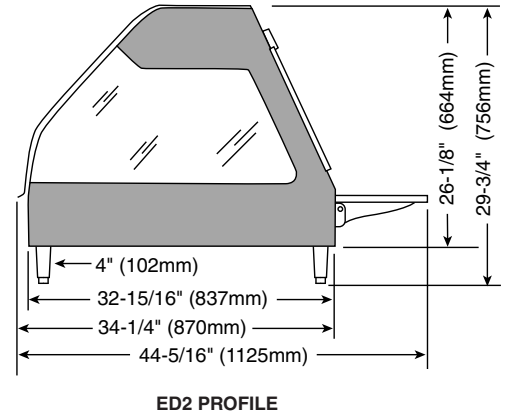
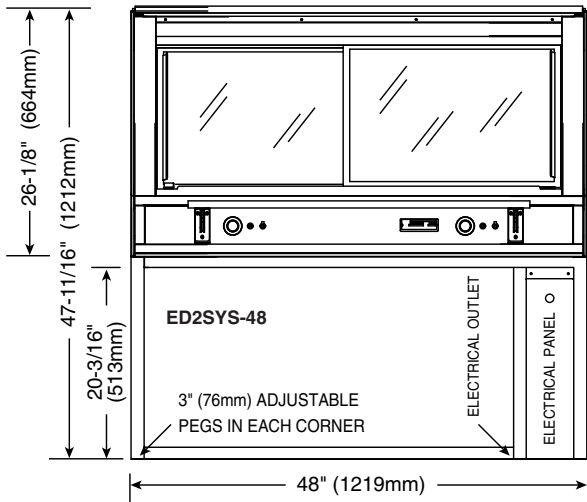

SITE INSTALLATION

EU2SYS SERIES

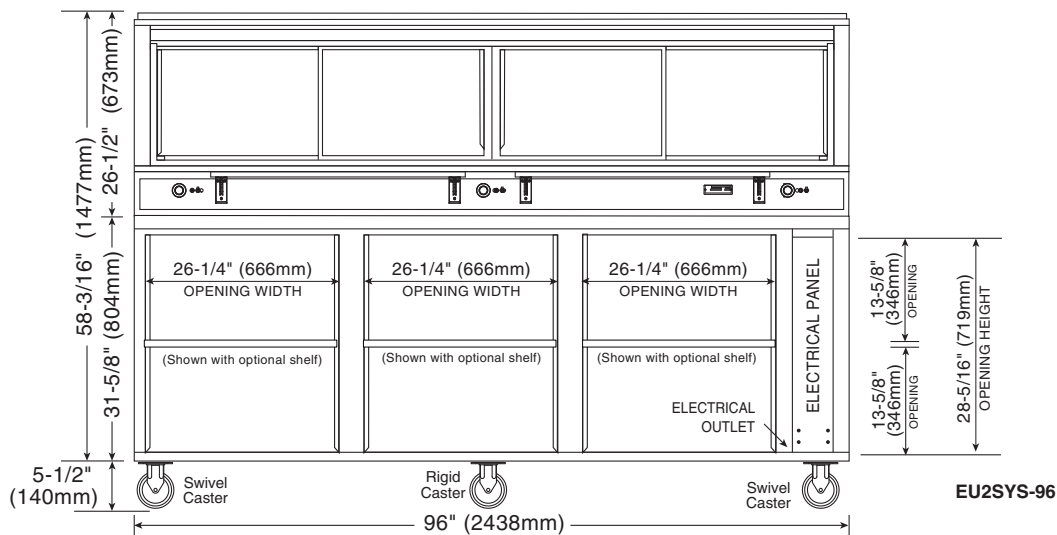
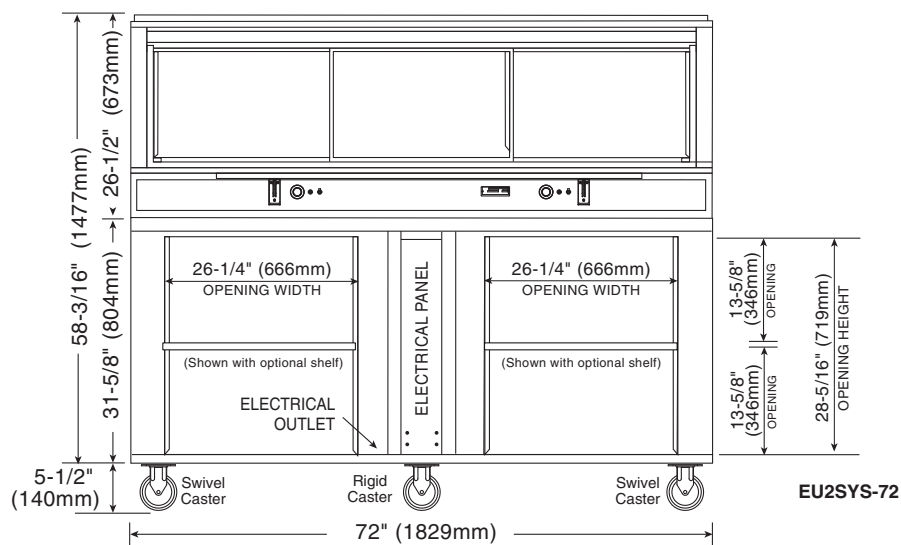
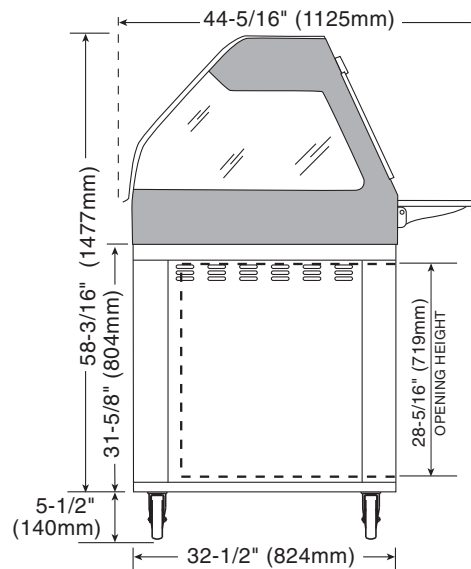
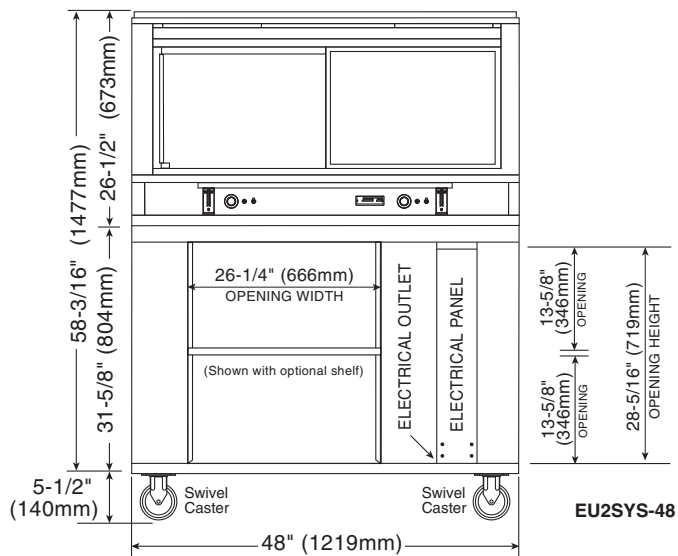

INSTALLATION

ELECTRICAL CONNECTION

The appliance must be installed by a qualified service technician. The oven must be properly grounded in accordance with the National Electrical Code and applicable local codes.

DANGER



To avoid electrical shock, this appliance MUST be adequately grounded in accordance with local electrical codes or, in the absence of local codes, with the current edition of the National Electrical Code ANSI/NFPA No. 70. In Canada, all electrical connections are to be made in accordance with CSA C22.1, Canadian Electrical Code Part 1 or local codes.



Plug the unit into a properly grounded receptacle **ONLY**, positioning the unit so that the plug is easily accessible in case of an emergency. Arcing will occur when connecting or disconnecting the unit unless all controls are in the “OFF” position.

Proper receptacle or outlet configuration or permanent wiring for this unit must be installed by a licensed electrician in accordance with applicable local electrical codes.

DANGER



ELECTRICAL CONNECTIONS MUST BE MADE BY A QUALIFIED SERVICE TECHNICIAN IN ACCORDANCE WITH APPLICABLE ELECTRICAL CODES.



DANGER



ENSURE POWER SOURCE MATCHES VOLTAGE STAMPED ON APPLIANCE NAMEPLATE.





REGARDING INTERNATIONAL STANDARD UNITS:

If the unit is not equipped with flexible cord with plug, an all-pole country approved disconnection device which has a contact separation of at least 3mm in all poles must be incorporated in the fixed wiring for disconnection. When using a cord without a plug, the green/yellow conductor shall be connected to the terminal which is marked with the ground symbol. If a plug is used, the socket outlet must be easily accessible. If the power cord needs replacement, use a similar one obtained from the distributor.

For 230V units: To prevent an electrical shock hazard between the appliance and other appliances or metal parts in close vicinity, an equalization-bonding stud is provided. An equalization bonding lead must be connected to this stud and the other appliances / metal parts to provide sufficient protection against potential difference. The terminal is marked with the following symbol.



ELECTRICAL						
ED2-48, ED2SYS-48, EU2SYS-48 SERIES						
VOLTAGE	PHASE	CYCLE/HZ	AMPS	kW		
120/208-240 (UL)	1	50/60	13.8	3.3	NEMA L14-20P 20A, 250V PLUG	
AT 208	1	50/60	11.6	2.5		
AT 240	1	50/60	13.0	3.1		
230 (CE)	1	50/60	12.6	2.9	BARE END, NO PLUG	
230	1	50/60	12.6	2.9		
ED2-72, ED2SYS-72, EU2SYS-72 SERIES						
VOLTAGE	PHASE	CYCLE/HZ	AMPS	kW		
120/208-240 (UL)	1	50/60	18.75	4.5	NEMA L14-30P 30A, 250V PLUG	
AT 208	1	50/60	19.0	4.6		
AT 240	1	50/60	19.0	4.6		
230 (CE)	1	50/60	18.3	4.2	BARE END, NO PLUG	
230	1	50/60	18.4	4.2		
380-415	3	50/60	10.5	4.4	BARE END, NO PLUG	
ED2-96, ED2SYS-96, EU2SYS-96 SERIES						
VOLTAGE	PHASE	CYCLE/HZ	AMPS	kW		
120/208-240 (UL)	1	50/60	24.0	5.2	NEMA L14-30P 30A, 250V PLUG	
AT 208	1	50/60	24.0	5.2		
AT 240	1	50/60	24.0	5.2		
230 (CE)	1	50/60	24.3	5.6	BARE END, NO PLUG	
230	1	50/60	24.7	5.7		
380-415	3	50/60	11.5	6.5	BARE END, NO PLUG	

INSTALLATION

ED2 & ED2SYS & EU2SYS SERIES — OPTIONS & ACCESSORIES

DESCRIPTION		ED2-48 SERIES	ED2-72 SERIES	ED2-96 SERIES
BUTTING KIT		5008523	5008523	5008523
CARVING STATION		5001874	5001874	5001874
CASTERS, PLATE (EU2SYS ONLY)	5" (127mm), RIGID	CS-2025 (2 REQ'D)	CS-2025 (2 REQ'D)	CS-2025 (2 REQ'D)
	5" (127mm), SWIVEL WITH BRAKE	CS-2026 (2 REQ'D)	CS-2026 (4 REQ'D)	CS-2026 (4 REQ'D)
GAUGE, INTERIOR AMBIENT TEMPERATURE	ED2-48, -48/P	5008527	—	—
	ED2-72, -72/P	—	5004182	—
	ED2-72/PR	—	5004183	—
	ED2-72/PL	—	5004184	—
	ED2-96	—	—	5004185
	ED2-96/PR	—	—	5004186
	ED2-96/PL	—	—	5004187
GLASS, TEMPERED END PANE, BRONZE KIT		5001143	5001143	5001143
INDEPENDENT ELECTRICAL OUTLET		5001781	5001781	5001781
LOW PROFILE BASE (EU2SYS ONLY)	OVERALL HEIGHT REDUCED BY 4-3/4" (121mm)	304332	304342	304352
PANEL KIT, COUNTER TOP	BRUSHED STAINLESS STEEL	5001281	5001282	5001283
	CUSTOM COLOR	P148	P152	P153
PANEL KIT, SYSTEM	BRUSHED STAINLESS STEEL	5001293	5001295	5001297
	CUSTOM COLOR	P154	P155	P156
PANEL KIT, SYSTEM (EU2SYS ONLY)	BRUSHED STAINLESS STEEL	5001287	5001289	5001291
	CUSTOM COLOR	5005788	5005790	5005793
PAN INSERT, SELF SERVICE	4" (102mm) DEEP	1001990	1001991	—
PLATFORM SCALE	RIGHT HAND	5001307	5001307	5001307
	LEFT HAND	5001308	5001308	5001308
SHELF, STAINLESS STEEL (EU2SYS ONLY)		5005786	5005786	5005786
SHEET PAN DIVIDER BAR PACKAGE	ED2-48, -48/P	5002802	—	—
	ED2-72, -72/P	—	5002803	—
	ED2-72/PL, -72/PR	—	5002804	—
	ED2-96	—	—	5002805
	ED2-96/PL, -96/PR	—	—	5002806
TEMPERATURE PROBE		5004916	5004917	5004918
THERMOSTAT GUARD COVER PLATE		5007660 (2 REQ'D)	5007660 (2 REQ'D)	5007660 (3 REQ'D)
WORK SHELF WITH GRAVY LANE	ED2-48, -48/P	5005638	—	—
	ED2-72, -72/P, -72/PL, -72/PR	—	5005639	—
	ED2-96, -96/P, -96/PL, -96/PR	—	—	5005640

OPERATING INSTRUCTIONS

USER SAFETY INFORMATION

CAUTION



METAL PARTS OF THIS EQUIPMENT BECOME EXTREMELY HOT WHEN IN OPERATION. TO AVOID BURNS, ALWAYS USE HAND PROTECTION WHEN OPERATING THIS APPLIANCE.

The Alto-Shaam heated display case is intended for use in commercial establishments by qualified operating personnel where all operators are familiar with the purpose, limitations, and associated hazards of this appliance. Operating instructions and warnings must be read and understood by all operators and users.

WARNING

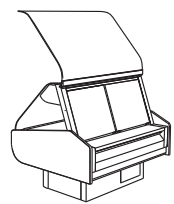

Hood glass extended to the full, upright portion is stabilized through the use of gas struts designed for the full, load-bearing weight. These struts could weaken or fail due to wear, environmental conditions or aging. OPERATORS SHOULD BE AWARE OF ANY DECREASE IN EFFORT TO LIFT THE HOOD AND INITIATE AN IMMEDIATE GAS STRUT SAFETY CHECK. DO NOT LIFT THE HOOD IN THIS CONDITION.

START-UP OPERATION

BEFORE INITIAL USE:

Interior display case surfaces must be heated to remove surface oils and the accompanying odor produced during the first use of the appliance.

Remove pans. Turn thermostats to the "ON" position. Set thermostats to the 10 setting. Allow the unit to heat for 30 minutes or until no odor is detected.

PREHEATING:

The unit should be preheated at the 10 setting for a minimum of 30-45 minutes before loading the case with hot food. Follow the operating instructions indicated on the next page of this manual.



DANGER



DISCONNECT UNIT FROM POWER SOURCE BEFORE CLEANING OR SERVICING.

DANGER



AT NO TIME SHOULD THE INTERIOR OR EXTERIOR BE STEAM CLEANED, HOSED DOWN, OR FLOODED WITH WATER OR LIQUID SOLUTION OF ANY KIND. DO NOT USE WATER JET TO CLEAN.



SEVERE DAMAGE OR ELECTRICAL HAZARD COULD RESULT.

WARRANTY BECOMES VOID IF APPLIANCE IS FLOODED

OPERATING INSTRUCTIONS

OPERATING PROCEDURES

1. DO NOT ADD WATER TO DISPLAY CASE

Halo Heat display cases maintain a constant but gentle temperature and eliminate much of the moisture loss associated with conventional display cases. Because of this gentle heat, it is not necessary to add water to the display case. As a matter of fact, **adding water is not recommended** since water will accelerate the deterioration of the product, and may damage the unit voiding the warranty.

2. PLACE DIVIDERS AND SERVING PANS IN CASE

Refer to the pan layout diagrams for different types of pan accommodations. A complete pan configuration layout is located in this manual. It is **VERY important to note**, no matter what type of pan configuration chosen, pan separator bars or divider bars must be used to close all gaps between pans, and all gaps between the pans and the edges of the display case. If these gaps are not closed, heat will escape from the bottom of the case into the display area. As a consequence, heat distribution will be uneven and uniform temperature will be difficult to hold. If needed, additional pan divider bars are available. The supplied self-serve pan inserts with wire grids are for use with pre-packaged foods in the self-serve sections of the units.

3. TURN DISPLAY LIGHTS "ON" AND SET THE THERMOSTAT(S) AT NUMBER "10" TO PREHEAT

A indicator light will illuminate when the thermostat(s) is (are) turned "ON." The indicator(s) will remain lit as long as the unit is preheating or calling for heat. The unit should be preheated at the 10 setting for a minimum of 30-45 minutes before loading the case with hot food. When preheating is completed, or whenever the unit reaches any temperature set by the operator between 1 and 10, the indicator light(s) will go "OUT".

4. LOAD HOT FOODS INTO DISPLAY CASE

Be certain only hot food is transferred into the display case. Before loading food into the case, use a pocket-type meat thermometer to make certain all products have reached an internal temperature of 140° to 160° F (60° to 71°C). If any food product is not at proper serving temperature, use a Halo Heat cooking and holding oven, set at 250° to 275°F (121° to 135°C), or a Combitherm oven to bring the product within the correct temperature range.

- Use hand protection when handling hot items.
- Be certain only hot PREPACKAGED foods in appropriate heat tested containers are used in the self-service section of the display case.
- Do not stack food containers.

5. RESET THERMOSTAT(S) AS NEEDED

After all products are loaded into the display case and the doors are closed, it is necessary to reset the thermostat(s). For fully enclosed sections, reset the thermostat to the number "8" setting. Cases with a self-service section should be maintained between number "9" and number "10" for the self-service section **only**. THESE SETTINGS WILL NOT NECESSARILY BE FINAL. Since proper temperature range depends on the type of products and the quantities being held, it is necessary to periodically use a pocket thermometer to check each item to make certain the correct temperatures are being maintained. Proper temperature range is between a minimum of 140° and 160°F (60° and 71°C). Normally, this will require a thermostat setting of between number "6" and "8" in fully enclosed cases. Self-service cases or sections will always require a higher thermostat setting.

6. PLACEMENT OF FOOD PROBE

If the unit is equipped with the probe accessory, wipe each probe and probe tip with a disposable alcohol pad to clean and sanitize before using. If the probe is left in its bracket, the LED temperature display will indicate the ambient air temperature inside the case. To place a probe into food kept in the case, remove the probe from the bracket and push the probe tip halfway into the product, positioning the tip at the center of the food mass. If placing into solid foods such as meat roast or poultry breasts, push the probe in from a straight downward position or in from the side to the center position. If placing into a semi-liquid or liquid product, the probe cable will probably need to be secured to keep the probe positioned properly. Do not let the probe tip touch the edges or sides. Tape the probe cable to the lip or edge of the container. Wipe each probe tip with a clean paper towel to remove food debris after each use. Follow by wiping probes with a disposable alcohol pad, and return each probe to the proper bracket position.

7. SERVE FRESH HOT FOOD

Keep hot foods looking fresh. Occasionally stir or rotate food as needed. Serve food products in appropriate heat tested packages or containers. Keep display case doors closed after serving. Wipe spills immediately to assure maximum eye appeal and to ease end of the day cleanup.

OPERATING INSTRUCTIONS

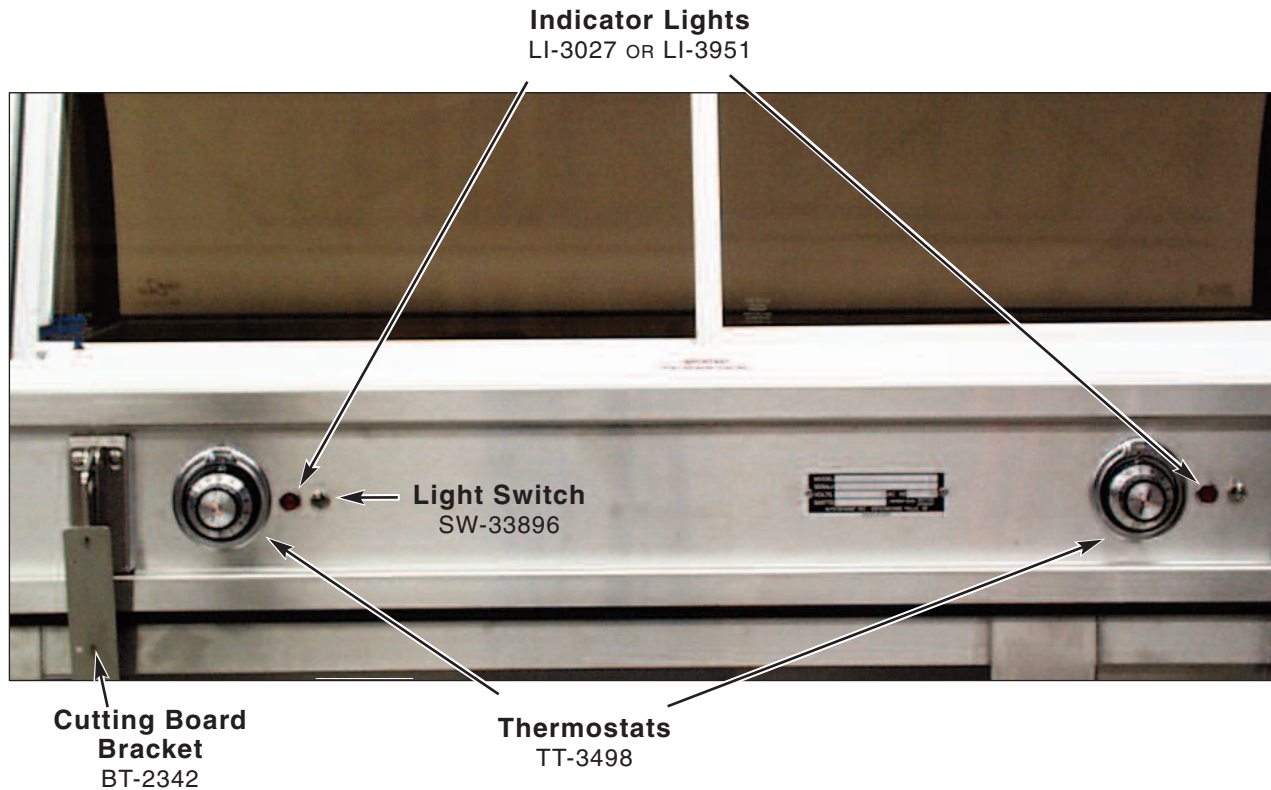

OPERATOR/CONTROL SIDE WITH CUTTING BOARD

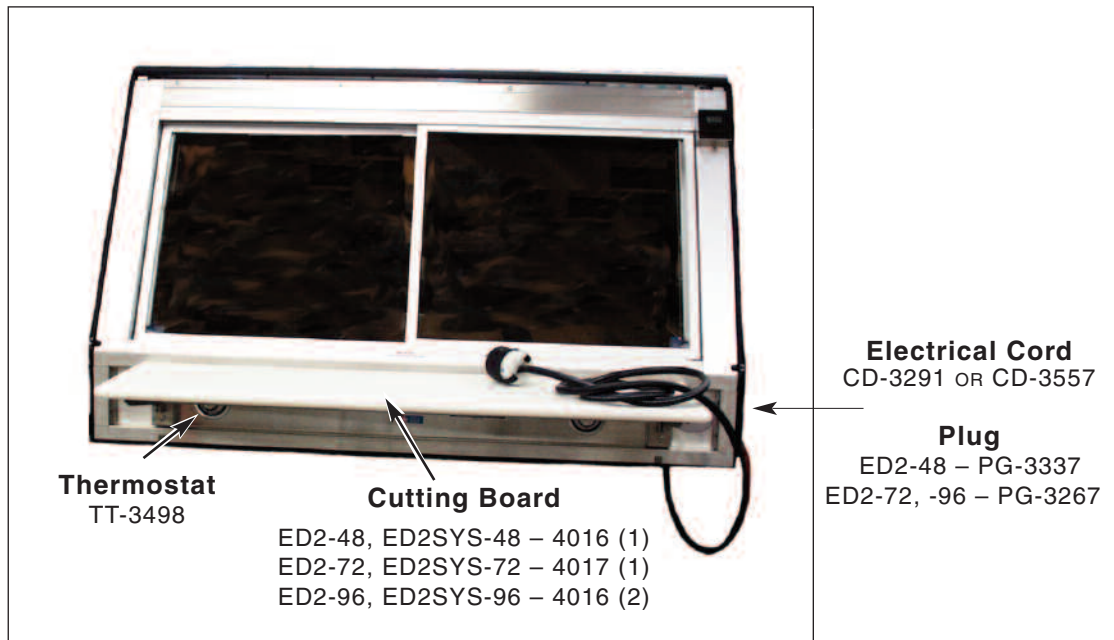

OPERATING INSTRUCTIONS

PAN CONFIGURATIONS • HEATED DISPLAY CASES

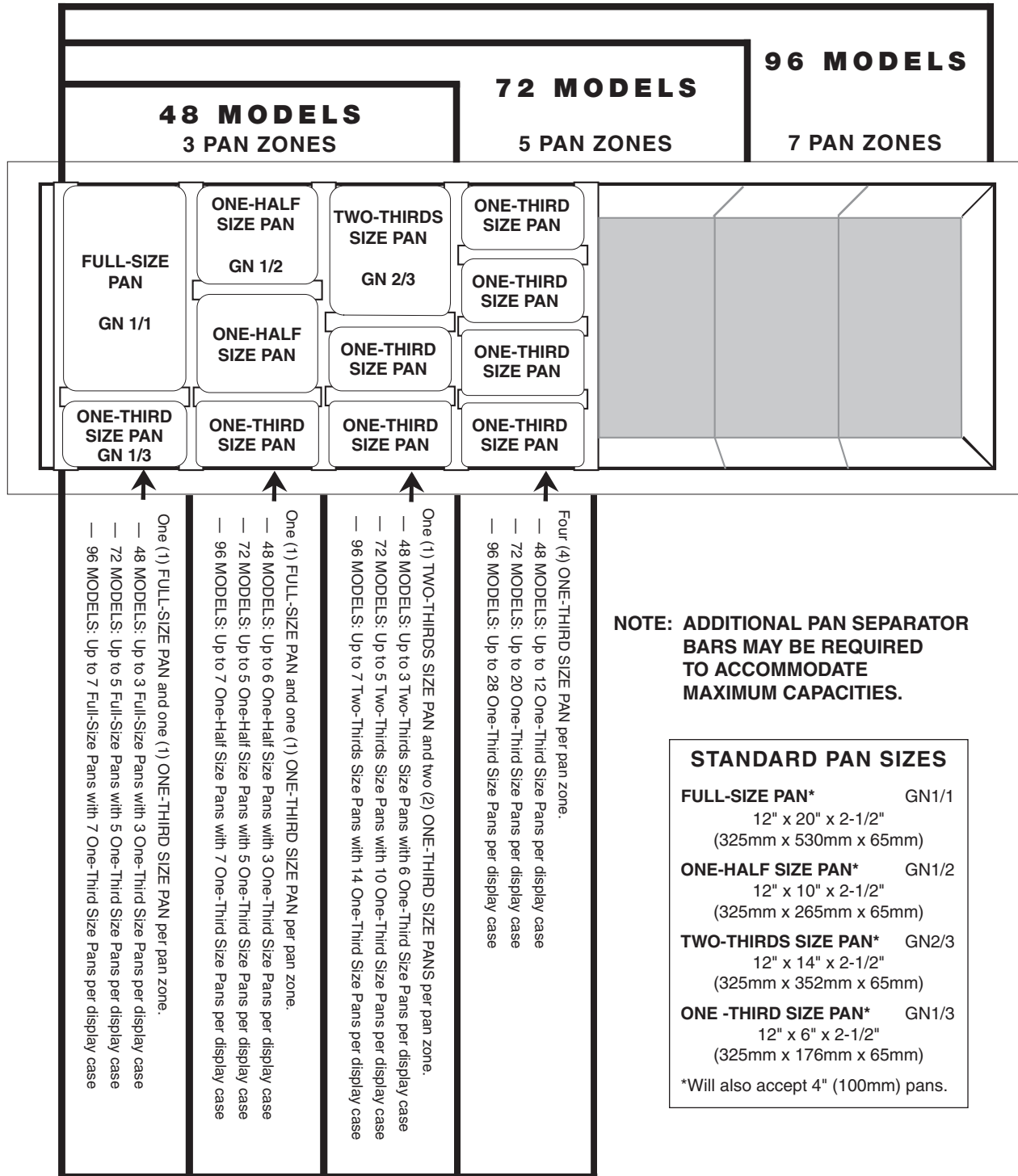

STANDARD PAN DIVIDER AND SEPARATOR BARS

PART NO.	DESCRIPTION	DIMENSIONS (W x L)	48	72	96
1002584	FULL, HALF AND THIRD SIZE-LONG	2-1/2" x 28" (64mm x 711mm)	4	4	—
1002590	FULL, HALF AND THIRD SIZE-LONG	1-13/16" x 28" (46mm x 711mm)	—	—	6
1002621	FULL, HALF AND THIRD SIZE-SHORT	1-15/32" x 13-1/2" (37mm x 343mm)	3	5	7
11318	FULL, HALF AND THIRD SIZE-SHORT	1" x 13-1/2" (25mm x 343mm)	9	15	21

OPERATING INSTRUCTIONS

PAN CONFIGURATIONS • SELF-SERVE HEATED DISPLAY CASES

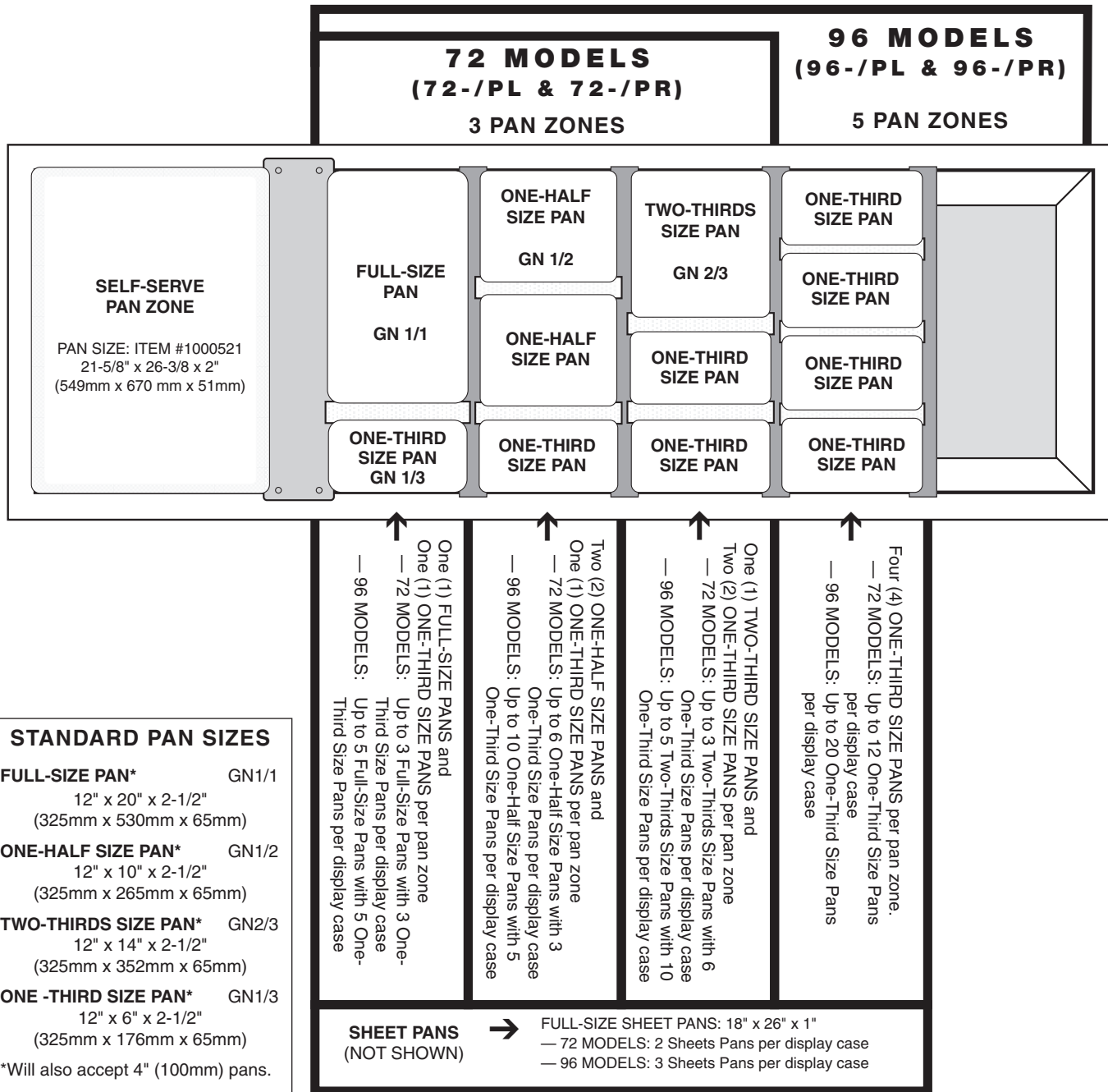

STANDARD PAN DIVIDER AND SEPARATOR BARS

PART NO.	DESCRIPTION	DIMENSIONS (W x L)	72	96
1002584	FULL, HALF AND THIRD SIZE-LONG	2-1/2" x 28" (64mm x 711mm)	4	—
1002590	FULL, HALF AND THIRD SIZE-LONG	1-13/16" x 28" (46mm x 711mm)	—	6
1002621	FULL, HALF AND THIRD SIZE-SHORT	1-15/32" x 13-1/2" (37mm x 343mm)	5	7
11318	FULL, HALF AND THIRD SIZE-SHORT	1" x 13-1/2" (25mm x 343mm)	15	21

OPERATING INSTRUCTIONS



MODEL >	48		72		96	
DESCRIPTION	PART NO.	QTY	PART NO.	QTY	PART NO.	QTY
INTERNATIONAL PAN DIVIDER KIT	5009135	1	5009136	1	5009137	1

BARS INCLUDED IN EACH KIT					
PART NO.	DESCRIPTION	DIMENSIONS (W x L)	48	72	96
1002585	GN 1/1, GN 1/2, GN 1/3 - Long	58 mm x 711 mm	4	4	—
1002591	GN 1/1, GN 1/2, GN 1/3 - Long	41 mm x 711 mm	—	—	6
1002619	GN 1/4	25 mm x 270 mm	6	10	14
1000544	GN 1/1, GN 1/2, GN 1/3 - Short	25 mm x 327 mm	9	15	21

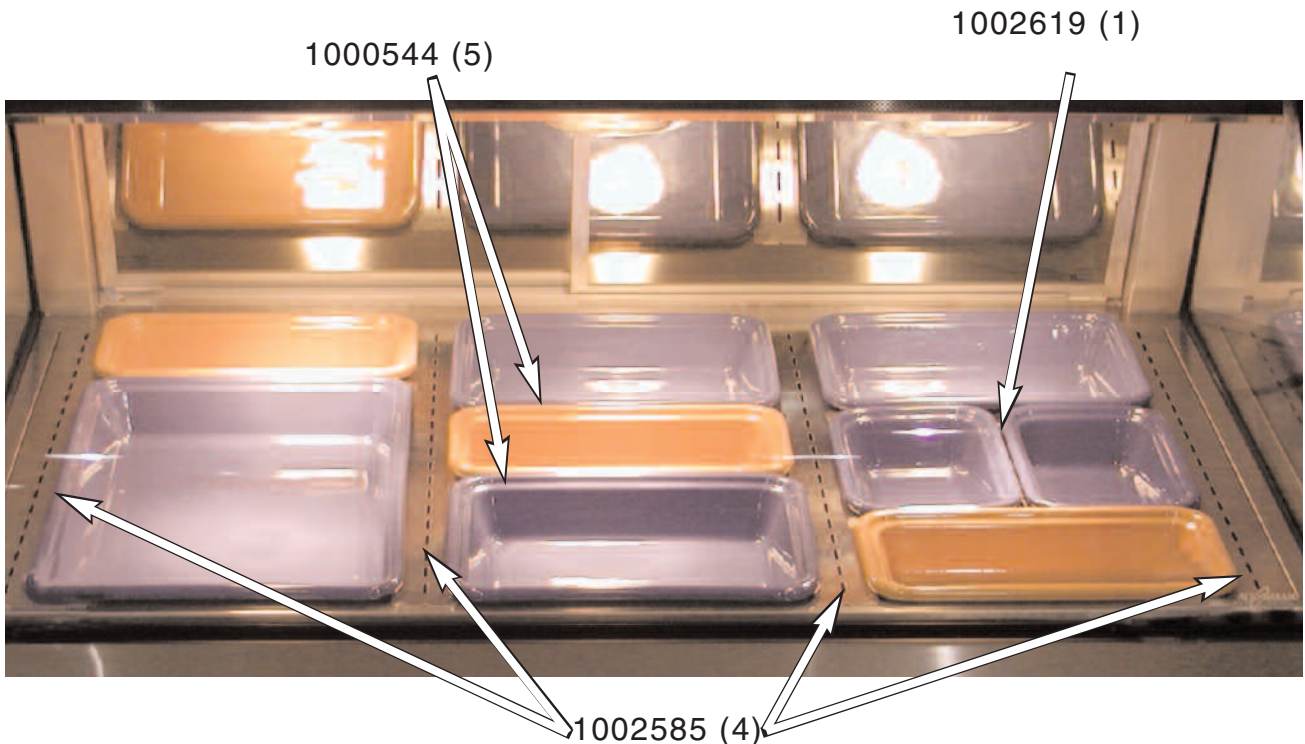

OPERATING INSTRUCTIONS

GENERAL HOLDING GUIDELINES

Chefs, cooks and other specialized food service personnel employ varied methods of cooking. Proper holding temperatures for a specific food product must be based on the moisture content of the product, product density, volume, and proper serving temperatures. Safe holding temperatures must also be correlated with palatability in determining the length of holding time for a specific product.

Halo Heat maintains the maximum amount of product moisture content without the addition of water, water vapor, or steam. Maintaining maximum natural product moisture preserves the natural flavor of the product and provides a more genuine taste. In addition to product moisture retention, the gentle properties of Halo Heat maintain a consistent temperature throughout the cabinet without the necessity of a heat distribution fan, thereby preventing further moisture loss due to evaporation or dehydration.

When product is removed from a high temperature cooking environment for immediate transfer into equipment with the lower temperature required for hot food holding, condensation can form on the outside of the product and on the inside of plastic containers used in self-service applications. Allowing the product to release the initial steam and heat produced by high temperature cooking can alleviate this condition. To preserve the safety and quality of freshly cooked foods however, a maximum of 1 to 2 minutes must be the only time period allowed for the initial heat to be released from the product.

The unit is equipped with a thermostat indicating a range of between 1 and 10. Use a metal-stemmed indicating thermometer to measure the internal temperature of the product(s) being held. Adjust the thermostat setting to achieve the best overall setting based on internal product temperature.

HOLDING TEMPERATURE RANGE		
MEAT	FAHRENHEIT	CELSIUS
BEEF ROAST — Rare	130°F	54°C
BEEF ROAST — Med/Well Done	155°F	68°C
BEEF BRISKET	160° — 175°F	71° — 79°C
CORN BEEF	160° — 175°F	71° — 79°C
PASTRAMI	160° — 175°F	71° — 79°C
PRIME RIB — Rare	130°F	54°C
STEAKS — Broiled/Fried	140° — 160°F	60° — 71°C
RIBS — Beef or Pork	160°F	71°C
VEAL	160° — 175°F	71° — 79°C
HAM	160° — 175°F	71° — 79°C
PORK	160° — 175°F	71° — 79°C
LAMB	160° — 175°F	71° — 79°C
POULTRY		
CHICKEN — Fried/Baked	160° — 175°F	71° — 79°C
DUCK	160° — 175°F	71° — 79°C
TURKEY	160° — 175°F	71° — 79°C
GENERAL	160° — 175°F	71° — 79°C
FISH/SEAFOOD		
FISH — Baked/Fried	160° — 175°F	71° — 79°C
LOBSTER	160° — 175°F	71° — 79°C
SHRIMP — Fried	160° — 175°F	71° — 79°C
BAKED GOODS		
BREADS/ROLLS	120° — 140°F	49° — 60°C
MISCELLANEOUS		
CASSEROLES	160° — 175°F	71° — 79°C
DOUGH — Proofing	80° — 100°F	27° — 38°C
EGGS — Fried	150° — 160°F	66° — 71°C
FROZEN ENTREES	160° — 175°F	71° — 79°C
HORS D'OEUVRES	160° — 180°F	71° — 82°C
PASTA	160° — 180°F	71° — 82°C
PIZZA	160° — 180°F	71° — 82°C
POTATOES	180°F	82°C
PLATED MEALS	140° — 165°F	60° — 74°C
SAUCES	140° — 200°F	60° — 93°C
SOUP	140° — 200°F	60° — 93°C
VEGETABLES	160° — 175°F	71° — 79°C
THE HOLDING TEMPERATURES LISTED ARE SUGGESTED GUIDELINES ONLY. ALL FOOD HOLDING SHOULD BE BASED ON INTERNAL PRODUCT TEMPERATURES. ALWAYS FOLLOW LOCAL HEALTH (HYGIENE) REGULATIONS FOR ALL INTERNAL TEMPERATURE REQUIREMENTS.		

CARE AND CLEANING

CLEANING AND PREVENTIVE MAINTENANCE

PROTECTING STAINLESS STEEL SURFACES



It is important to guard against corrosion in the care of stainless steel surfaces. Harsh, corrosive, or inappropriate chemicals can completely destroy the

protective surface layer of stainless steel. Abrasive pads, steel wool, or metal implements will abrade surfaces causing damage to this protective coating and will eventually result in areas of corrosion. Even water, particularly hard water that contains high to moderate concentrations of chloride, will cause oxidation and pitting that result in rust and corrosion. In addition, many acidic foods spilled and left to remain on metal surfaces are contributing factors that will corrode surfaces.

Proper cleaning agents, materials, and methods are vital to maintaining the appearance and life of this appliance. Spilled foods should be removed and the area wiped as soon as possible but at the very least, a minimum of once a day. Always thoroughly rinse surfaces after using a cleaning agent and wipe standing water as quickly as possible after rinsing.

CLEANING AGENTS

Use non-abrasive cleaning products designed for use on stainless steel surfaces. Cleaning agents must be chloride-free compounds and must not contain quaternary salts. Never use hydrochloric acid (muriatic acid) on stainless steel surfaces. Always use the proper cleaning agent at the manufacturer's recommended strength. Contact your local cleaning supplier for product recommendations.

CLEANING MATERIALS

The cleaning function can usually be accomplished with the proper cleaning agent and a soft, clean cloth. When more aggressive methods must be employed, use a non-abrasive scouring pad on difficult areas and make certain to scrub with the visible grain of surface metal to avoid surface scratches. Never use wire brushes, metal scouring pads, or scrapers to remove food residue.

 CAUTION	
 NO SCRAPERS	TO PROTECT STAINLESS STEEL SURFACES, COMPLETELY AVOID THE USE OF ABRASIVE CLEANING COMPOUNDS, CHLORIDE BASED CLEANERS, OR CLEANERS CONTAINING QUATERNARY SALTS. NEVER USE HYDROCHLORIC ACID (MURIATIC ACID) ON STAINLESS STEEL. NEVER USE WIRE BRUSHES, METAL SCOURING PADS OR SCRAPERS.
 NO WIRE BRUSHES	
 NO STEEL PADS	

CARE AND CLEANING

EQUIPMENT CARE

Under normal circumstances, this appliance should provide you with long and trouble free service. There is no preventative maintenance required, however, the following Equipment Care Guide will maximize the potential life and trouble free operation of this appliance. The cleanliness and appearance of this equipment will contribute considerably to operating efficiency and savory, appetizing food. Good equipment that is kept clean works better and lasts longer.



CLEAN THE PROBES DAILY

If the display case is supplied with probes, remove all food soil from probes. Wipe entire probe and cable assembly with warm detergent solution and a clean cloth. Remove detergent by wiping each probe and cable with clean rinse water and a cloth. Wipe probes with disposable alcohol pad or sanitizing solution recommended for food contact surfaces. Allow probe and cable to air dry in probe holding bracket.



CLEAN DAILY

- Turn lights and adjustable thermostat(s) to the "OFF" position, and disconnect unit from power source.
- Remove, cover or wrap, and store unused products under refrigeration.
- Clean the interior metal surfaces of the cabinet with a damp clean cloth and any good commercial detergent or grease solvent at the recommended strength. Use a plastic scouring pad or oven cleaner for difficult areas. Rinse well to remove all residue and wipe dry.

NOTE: Avoid the use of abrasive cleaning compounds, chloride based cleaners, or cleaners containing quaternary salts. Never use hydrochloric acid (muriatic acid) on stainless steel.

- Clean the glass with a window cleaner. The sliding glass doors are removable allowing for easier cleaning.
- To help maintain the protective film coating on polished stainless steel, clean the exterior of the unit with a cleaner recommended for stainless steel surfaces. Spray the cleaning agent on a clean cloth and wipe with the grain of the stainless steel.

Always follow appropriate state or local health (hygiene) regulations regarding all applicable cleaning and sanitation requirements for equipment.

CHECK OVERALL CONDITION ONCE A MONTH

Check the case and related cabinets once a month for physical damage and loose screws. Correct any problems before they begin to interfere with the operation of the unit.

DO NOT USE APPLIANCE IF CONTROLS ARE NOT PROPERLY FUNCTIONING

Refer to the Trouble Shooting Guide located in this manual or call an authorized service technician.

DANGER



AT NO TIME SHOULD THE INTERIOR OR EXTERIOR BE STEAM CLEANED, HOSED DOWN, OR FLOODED WITH WATER OR LIQUID SOLUTION OF ANY KIND. DO NOT USE WATER JET TO CLEAN.



SEVERE DAMAGE OR ELECTRICAL HAZARD COULD RESULT.

WARRANTY BECOMES VOID IF APPLIANCE IS FLOODED

WARNING



Hood glass extended to the full, upright portion is stabilized through the use of gas struts designed for the full, load-bearing weight. These struts could weaken or fail due to wear, environmental conditions or aging. OPERATORS SHOULD BE AWARE OF ANY DECREASE IN EFFORT TO LIFT THE HOOD AND INITIATE AN IMMEDIATE GAS STRUT SAFETY CHECK. **DO NOT LIFT THE HOOD IN THIS CONDITION.**



CAUTION



The performance of this unit has been optimized using the factory provided bulbs. These bulbs should be replaced with an exact replacement or with a factory recommended replacement. These bulbs have been treated to resist breakage and must be replaced with similarly treated bulbs in order to maintain compliance with NSF standards. **DO NOT** over-tighten bulbs in their receptacles as this can cause damage to the bulb filament.

Food flavor and aroma are usually so closely related that it is difficult, if not impossible, to separate them. There is also an important, inseparable relationship between cleanliness and food flavor. Cleanliness, top operating efficiency, and appearance of equipment contribute considerably to savory, appetizing foods. Good equipment that is kept clean, works better and lasts longer.

Most food imparts its own particular aroma and many foods also absorb existing odors. Unfortunately, during this absorption, there is no distinction between GOOD and BAD odors. The majority of objectionable flavors and odors troubling food service operations are caused by bacteria growth. Sourness, rancidity, mustiness, stale or other OFF flavors are usually the result of germ activity.

The easiest way to insure full, natural food flavor is through comprehensive cleanliness. This means good control of both visible soil (dirt) and invisible soil (germs). A thorough approach to sanitation will provide essential cleanliness. It will assure an attractive appearance of equipment, along with maximum efficiency and utility. More importantly, a good sanitation program provides one of the key elements in the prevention of food-borne illnesses.

A controlled holding environment for prepared foods is just one of the important factors involved in the prevention of food-borne illnesses. Temperature monitoring and control during receiving, storage, preparation, and the service of foods are of equal importance.

The most accurate method of measuring safe temperatures of both hot and cold foods is by internal product temperature. A quality thermometer is an effective tool for this purpose, and should be routinely used on all products that require holding at a specific temperature.

A comprehensive sanitation program should focus on the training of staff in basic sanitation procedures. This includes personal hygiene, proper handling of raw foods, cooking to a safe internal product temperature, and the routine monitoring of internal temperatures from receiving through service.

Most food-borne illnesses can be prevented through proper temperature control and a comprehensive program of sanitation. Both these factors are important to build quality service as the foundation of customer satisfaction. Safe food handling practices to prevent food-borne illness is of critical importance to the health and safety of your customers.

HACCP, an acronym for Hazard Analysis (at) Critical Control Points, is a quality control program of operating procedures to assure food integrity, quality, and safety. Taking steps necessary to augment food safety practices are both cost effective and relatively simple. While HACCP guidelines go far beyond the scope of this manual, additional information is available by contacting:

**CENTER FOR FOOD SAFETY AND APPLIED
NUTRITION FOOD AND DRUG ADMINISTRATION
1-888-SAFEFOOD**

INTERNAL FOOD PRODUCT TEMPERATURES		
HOT FOODS		
DANGER ZONE	40° TO 140°F	(4° TO 60°C)
CRITICAL ZONE	70° TO 120°F	(21° TO 49°C)
SAFE ZONE	140° TO 165°F	(60° TO 74°C)
COLD FOODS		
DANGER ZONE	ABOVE 40°F	(ABOVE 4°C)
SAFE ZONE	36°F TO 40°F	(2°C TO 4°C)
FROZEN FOODS		
DANGER ZONE	ABOVE 32°F	(ABOVE 0°C)
CRITICAL ZONE	0° TO 32°F	(-18° TO 0°C)
SAFE ZONE	0°F or below	(-18°C or below)

SERVICE

ED2 SERIES - SERVICE VIEWS

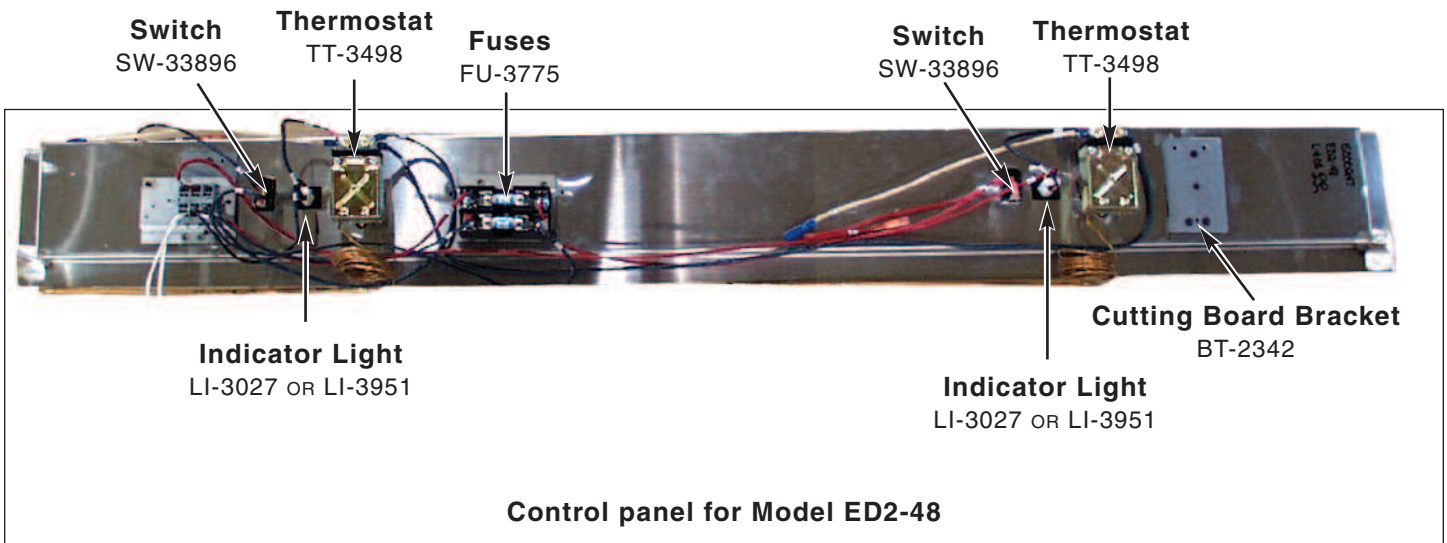
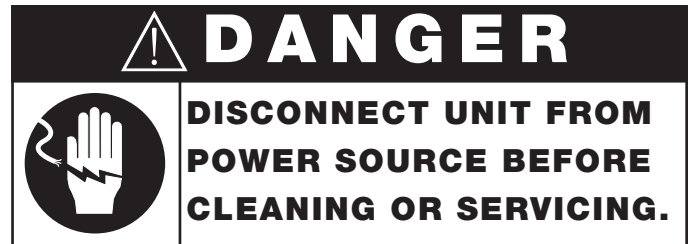
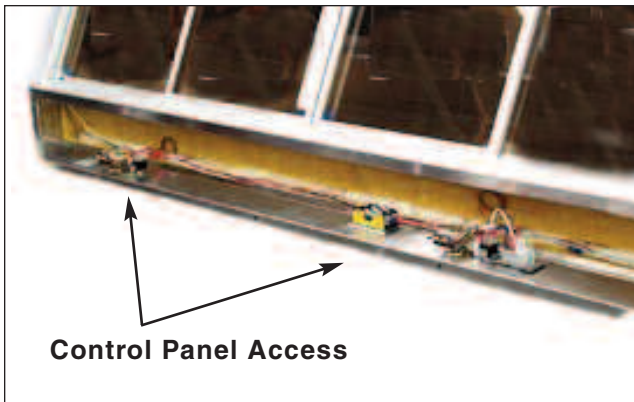

ED2 SERIES - SERVICE VIEWS

Inside the top - lights

LP-33783 (230V)
LP-33592 (120/208-240V)



Bulb Receptacles

RP-3955 (230V)
RP-3952 (120/208-240V)

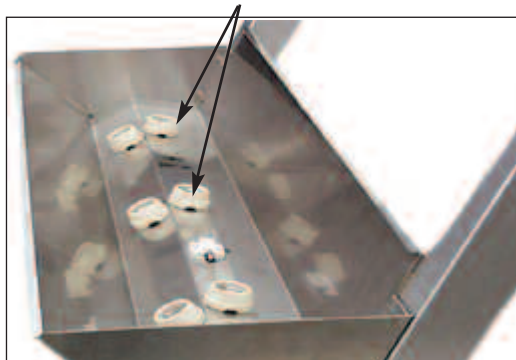

CAUTION



The performance of this unit has been optimized using the factory provided bulbs. These bulbs should be replaced with an exact replacement or with a factory recommended replacement. These bulbs have been treated to resist breakage and must be replaced with similarly treated bulbs in order to maintain compliance with NSF standards. **DO NOT** over-tighten bulbs in their receptacles as this can cause damage to the bulb filament.

Manual Temperature Gauge (option)

5008527 (ED2-48, -48/P)	5004185 (ED2-96)
5004182 (ED2-72, -72/P)	5004186 (ED2-96/PR)
5004183 (ED2-72/PR)	5004187 (ED2-96/PL)
5004184 (ED2-72/PL)	



Hinge Repair Kit

HG-28160

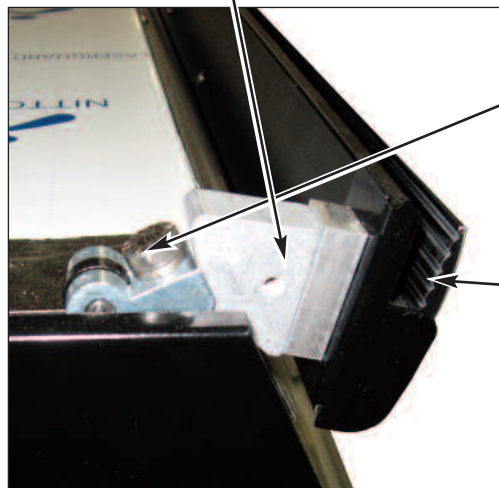

Gas Ram Bolt

REMOVE TO SERVICE GAS RAM.

Glass Clamp

CM-26765
(ED2-48 SERIES)
CM-26766
(ED2-72 SERIES)
CM-26767
(ED2-96 SERIES)

SERVICE

ED2 SERIES - SERVICE VIEWS

Upper Door Track

(NOT SHOWN)
TK-26752 (48)
TK-26754 (72)
TK-26756 (96)

Lower Door Track

TK-26751 (48)
TK-26753 (72)
TK-26755 (96)

Door Assembly

RIGHT-HAND DR-25424 MIDDLE DR-25423 LEFT-HAND DR-25422

Glass Clamp

CM-26765 (48)
CM-26766 (72)
CM-26767 (96)

End Glass
LEFT OR RIGHT
GL-25762

End Panel
1005367

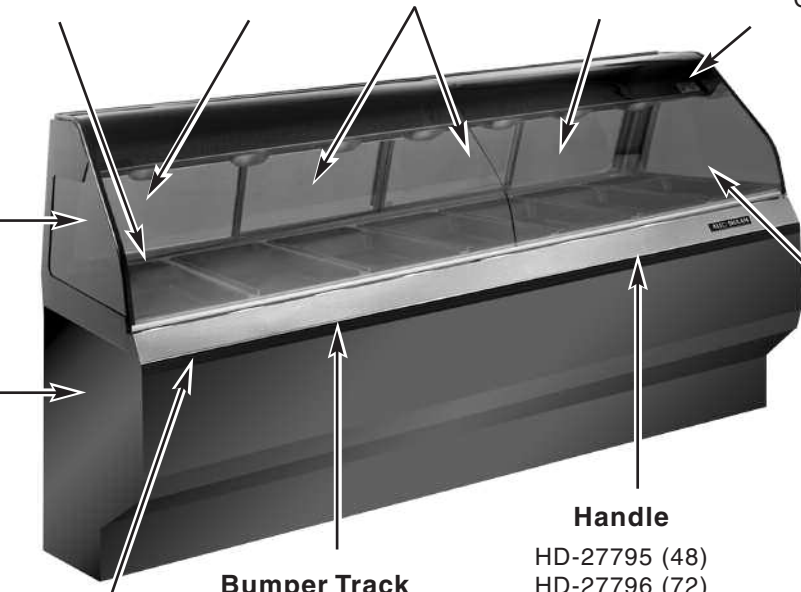

Bumper
BM-24082

Bumper Track

1001949 (48)
1001950 (72)
1001951 (96)

Handle

HD-27795 (48)
HD-27796 (72)
HD-27797 (96)

Front Glass, Full Service

GL-25420 (48 - 1 REQ'D)
GL-25785 (72 - 1 REQ'D)
GL-25420 (96 - 2 REQ'D)

CABLE REPLACEMENT KITS

ED2-48 SERIES CABLE REPLACEMENT KIT

CABLE HEATING SERVICE KIT NO. 4880

INCLUDES:

CB-3045	CABLE HEATING ELEMENT	.134 FEET
CR-3226	RING CONNECTOR	.4
IN-3488	INSULATION CORNER	.1 FOOT
BU-3105	SHOULDER BUSHING	.4
BU-3106	CUP BUSHING	.4
SL-3063	INSULATING SLEEVE	.4
TA-3540	HIGH TEMPERATURE TAPE	.1 ROLL
ST-2439	STUD, 10/32	.4
NU-2215	HEX NUT	.8

ED2-72 SERIES CABLE REPLACEMENT KIT

CABLE HEATING SERVICE KIT NO. 4881

INCLUDES:

CB-3045	CABLE HEATING ELEMENT	.210 FEET
CR-3226	RING CONNECTOR	.12
IN-3488	INSULATION CORNER	.1 FOOT
BU-3105	SHOULDER BUSHING	.12
BU-3106	CUP BUSHING	.12
SL-3063	INSULATING SLEEVE	.12
TA-3540	HIGH TEMPERATURE TAPE	.1 ROLL
ST-2439	STUD, 10/32	.12
NU-2215	HEX NUT	.24

ED2-96 SERIES CABLE REPLACEMENT KIT

CABLE HEATING SERVICE KIT NO. 14228

INCLUDES:

CB-3045	CABLE HEATING ELEMENT	.280 FEET
CR-3226	RING CONNECTOR	.8
IN-3488	INSULATION CORNER	.1 FOOT
BU-3105	SHOULDER BUSHING	.8
BU-3106	CUP BUSHING	.8
SL-3063	INSULATING SLEEVE	.8
TA-3540	HIGH TEMPERATURE TAPE	.1 ROLL
ST-2439	STUD, 10/32	.8
NU-2215	HEX NUT	.16

CAUTION



The performance of this unit has been optimized using the factory provided bulbs. These bulbs should be replaced with an exact replacement or with a factory recommended replacement. These bulbs have been treated to resist breakage and must be replaced with similarly treated bulbs in order to maintain compliance with NSF standards. **DO NOT** over-tighten bulbs in their receptacles as this can cause damage to the bulb filament.



DANGER



DISCONNECT UNIT FROM POWER SOURCE BEFORE CLEANING OR SERVICING.

ED2-48 SERIES

PART DESCRIPTION	PART NO.	ED2-48	ED2-48/P	ED2S-YS-48	ED2S-YS-48/P
1. BULBS RECEPTACLE, BULB	120V LP-33592	6	6	6	6
	230V LP-33783	6	6	6	6
	120V RP-3952	6	6	6	6
	230V RP-3955	6	6	6	6
2. BUMPER	GLASS BM-22721	1	1	1	1
	END CAP BM-22722	2	2	2	2
	TRACK 1001949	1	1	1	1
3. CLAMP, GLASS	CM-26765	1	1	1	1
4. CONTROL PANEL	1000623	1	1	1	1
5. CORD; 7ft (2133mm)	120V CD-3291	1	1	1	1
	230V CD-33490	1	1	1	1
6. CUTTING BOARD ASSEMBLY, 4ft (1219mm)	4016	1	1	1	1
	BRACKET BT-2342	2	2	2	2
	BRACKET BASE 11283	2	2	2	2
7. DOOR, GLASS	LEFT-HAND DR-25422	1	1	1	1
	RIGHT-HAND DR-25423	1	1	1	1
8. END PANELS, BLACK	1005367	2	2	2	2
9. EQUIPOTENTIAL STUD (230V ONLY)	ST-24173	1	1	1	1
10. FUSE HOLDER FUSE, 15 AMP	FU-3772	1	1	1	1
	FU-3775	2	2	2	2
11. GLASS, END GASKET, END GLASS	GL-25762	2	2	2	2
	GS-22547	2	2	2	2
12. GLASS, FRONT	FULL-SERVE GL-25420	1	—	1	—
	SELF-SERVE GL-25586	—	1	—	1
13. HANDLE, GLASS	HD-27795	1	1	1	1
14. HEATING CABLE KIT, 132ft (40234mm)	4880	X	X	X	X
15. HINGE ASSEMBLY (INCLUDES SUPPORT) HINGE REPAIR KIT	LEFT-HAND HG-26764	1	1	1	1
	RIGHT-HAND HG-26763	1	1	1	1
	HG-28160	1	1	1	1
16. INDICATOR LIGHT, WHITE	LI-3951	2	2	2	2
17. INSULATION	IN-22364	1	1	1	1
	IN-2003	1	1	1	1
18. LEGS, 4" (102mm)	LG-2044	4	4	—	—
19. PAN DIVIDERS, SEE PAGES 11-13					
20. PANEL, FRONT	UPPER 1005213	1	1	1	1
	LOWER 1005342	1	1	1	1
21. PLUG	PG-3337	1	1	1	1
22. SWITCH, TOGGLE	SW-33896	2	2	2	2
23. TERMINAL BLOCK	MODULAR BK-25432	1	1	1	1
24. THERMOSTAT THERMOSTAT KNOB THERMOSTAT, BEZEL	TT-3498	2	2	2	2
	KN-3473	2	2	2	2
	TT-3713	2	2	2	2
25. TRACK, DOOR	BOTTOM TK-26751	1	1	1	1
	TOP TK-26752	1	1	1	1
26. STRUTS, GAS	SU-26849	2	2	2	2

ED2-72 SERIES

PART DESCRIPTION	PART NO.	ED2-72	ED2-72/P	ED2-72/PL	ED2-72/PR	ED2SYS-72	ED2SYS-72/P	ED2SYS-72/PL	ED2SYS-72/PR
1. BULBS 120V 230V & 380-415V RECEPTACLE, BULB 120V 230V & 380-415V	LP-33592	10	10	10	10	10	10	10	10
	LP-33783	10	10	10	10	10	10	10	10
	RP-3952	10	10	10	10	10	10	10	10
	RP-3955	10	10	10	10	10	10	10	10
2. BUMPER GLASS END CAP TRACK	BM-22721	1	1	1	1	1	1	1	1
	BM-22722	2	2	2	2	2	2	2	2
	1001950	1	1	1	1	1	1	1	1
3. CLAMP, GLASS	CM-26766	1	1	1	1	1	1	1	1
4. CONTROL PANEL	1001252	1	1	1	1	1	1	1	1
5. CORD; 7ft (2133mm) 120V 230V 380-415V	CD-3557	1	1	1	1	1	1	1	1
	CD-33490	1	1	1	1	1	1	1	1
	CD-3727	1	1	1	1	1	1	1	1
6. CUTTING BOARD ASSEMBLY, 6ft (1829mm) BRACKET BRACKET BASE	4017	1	1	1	1	1	1	1	1
	BT-2342	2	2	2	2	2	2	2	2
	11283	2	2	2	2	2	2	2	2
7. DOOR, GLASS LEFT-HAND MIDDLE RIGHT-HAND	DR-25422	1	1	1	1	1	1	1	1
	DR-25423	1	1	1	1	1	1	1	1
	DR-25424	1	1	1	1	1	1	1	1
8. END PANELS, BLACK	1005367	2	2	2	2	2	2	2	2
9. EQUIPOTENTIAL STUD (230V ONLY)	ST-24173	1	1	1	1	1	1	1	1
10. FUSE HOLDER FUSE, 15 AMP	FU-3772	1	1	1	1	1	1	1	1
	FU-3775	2	2	2	2	1	1	1	1
11. GLASS, END GASKET, END GLASS	GL-25762	2	2	2	2	2	2	2	2
	GS-22547	2	2	2	2	2	2	2	2
12. GLASS, FRONT FULL-SERVE SELF-SERVE	GL-25785	1	—	1	1	1	—	1	1
	GL-25889	—	1	—	—	—	1	—	—
	GL-25430	—	—	1	1	—	—	1	1
13. HANDLE, GLASS	HD-27796	1	1	1	1	1	1	1	1
14. HEATING CABLE KIT, 210ft (64008mm)	4881	X	X	X	X	X	X	X	X
15. HINGE ASSEMBLY (INCLUDES SUPPORT) HINGE REPAIR KIT	LEFT-HAND HG-26764	1	1	1	1	1	1	1	1
	RIGHT-HAND HG-26763	1	1	1	1	1	1	1	1
	HG-28160	1	1	1	1	1	1	1	1
16. INDICATOR LIGHT, WHITE 120V 230V & 380-415V	LI-3027	2	2	2	2	2	2	2	2
	LI-3951	2	2	2	2	2	2	2	2
17. INSULATION	IN-22364	1	1	1	1	1	1	1	1
	IN-2003	1	1	1	1	1	1	1	1
18. LEGS, 4" (102mm)	LG-2044	4	4	4	4	—	—	—	—
19. PAN DIVIDERS, SEE PAGES 11-13									
20. PANEL, FRONT UPPER LOWER	1005213	1	1	1	1	1	1	1	1
	1005342	1	1	1	1	1	1	1	1
21. PLUG	PG-3267	1	1	1	1	1	1	1	1
22. SWITCH, TOGGLE	SW-33896	2	2	2	2	2	2	2	2
23. TERMINAL BLOCK MODULAR POWER	BK-25432	1	1	1	1	1	1	1	1
	BK-3021	—	1	1	1	—	1	1	1
24. THERMOSTAT THERMOSTAT KNOB THERMOSTAT, BEZEL	TT-3498	2	2	2	2	2	2	2	2
	KN-3473	2	2	2	2	2	2	2	2
	TT-3713	2	2	2	2	2	2	2	2
25. TRACK, DOOR BOTTOM TOP	TK-26753	1	1	1	1	1	1	1	1
	TK-26754	1	1	1	1	1	1	1	1
26. STRUTS, GAS	SU-26850	2	2	2	2	2	2	2	2

ED2-96 SERIES

PART DESCRIPTION	PART NO.	ED2-96	ED2-96/PL	ED2-96/PR	ED2SYS-96	ED2SYS-96/PL	ED2SYS-96/PR
1. BULBS RECEPTACLE, BULB	120V 230V & 380-415V	LP-33592	14	14	14	14	14
		LP-33783	14	14	14	14	14
	120V	RP-3952	14	14	14	14	14
	230V & 380-415V	RP-3955	14	14	14	14	14
2. BUMPER	GLASS	BM-22721	1	1	1	1	1
	END CAP	BM-22722	2	2	2	2	2
	TRACK	1001951	1	1	1	1	1
3. CLAMP, GLASS		CM-26767	1	1	1	1	1
4. CONTROL PANEL		1001467	1	1	1	1	1
5. CORD; 7ft (2133mm)	120V	CD-3557	1	1	1	1	1
	230V	CD-33490	1	1	1	1	1
	380-415V	CD-3727	1	1	1	1	1
6. CUTTING BOARD ASSEMBLY, 4ft (1219mm)		4016	2	2	2	2	2
	BRACKET	BT-2342	4	4	4	4	4
	BRACKET BASE	11283	4	4	4	4	4
7. DOOR, GLASS	LEFT-HAND	DR-25422	1	1	1	1	1
	MIDDLE	DR-25423	2	2	2	2	2
	RIGHT-HAND	DR-25424	1	1	1	1	1
8. END PANELS, BLACK		1005367	2	2	2	2	2
9. EQUIPOTENTIAL STUD (230V ONLY)		ST-24173	1	1	1	1	1
10. FUSE HOLDER FUSE, 15 AMP		FU-3772	1	1	1	1	1
		FU-3775	2	2	2	1	1
11. GLASS, END GASKET, END GLASS		GL-25762	2	2	2	2	2
		GS-22547	2	2	2	2	2
12. GLASS, FRONT	FULL-SERVE	GL-25420	2	—	—	2	—
	SELF-SERVE	GL-25430	—	1	1	—	1
13. HANDLE, GLASS		HD-27797	1	1	1	1	1
14. HEATING CABLE KIT, 280ft (85344mm)		14228	X	X	X	X	X
15. HINGE ASSEMBLY	LH & RH	HG-27340	2	2	2	2	2
16. INDICATOR LIGHT, WHITE	120V	LI-3027	3	3	3	3	3
	230V & 380-415V	LI-3951	3	3	3	3	3
17. INSULATION		IN-22364	1	1	1	1	1
		IN-2003	1	1	1	1	1
18. LEGS, 4" (102mm)		LG-2044	6	6	6	—	—
19. PAN DIVIDERS, SEE PAGES 11-13							
20. PANEL, FRONT	UPPER	1005213	1	1	1	1	1
	LOWER	1005342	1	1	1	1	1
21. PLUG		PG-3267	1	1	1	1	1
22. SWITCH, TOGGLE		SW-33896	3	3	3	3	3
23. TERMINAL BLOCK	MODULAR	BK-25432	1	1	1	1	1
	POWER	BK-3021	1	1	1	1	1
24. THERMOSTAT THERMOSTAT KNOB THERMOSTAT, BEZEL		TT-3498	3	3	3	3	3
		KN-3473	3	3	3	3	3
		TT-3713	3	3	3	3	3
25. TRACK, DOOR	BOTTOM	TK-26755	1	1	1	1	1
	TOP	TK-26756	1	1	1	1	1
26. STRUTS, GAS		SU-26849	4	—	—	4	—
		SU-26851	—	2	2	—	2



EU2SYS-48

FRONT VIEW ED2-48 ON BU2-48 CART WITH OPTIONAL CASTERS



EU2SYS-48

REAR VIEW ED2-48 ON BU2-48 CART WITH SHELF

EU2-48 SERIES

PART DESCRIPTION

PART NO.

EU2SYS-48

EU2SYS-48/P

1. BUSHING, STRAIN RELIEF	BU-3011	1	1
2. BUSHING, SNAP	BU-3378	1	1
3. CASTERS, PLATE	1002149	4	4
4. CORD, 6ft (1828mm)	CD-3607	1	1
5. FAN	FA-3568	1	1
6. FAN CORD	CD-33338	1	1
7. PANELS	1006857	4	4
8. TERMINAL BLOCK	BK-3023	2	2

EU2-72 SERIES

PART DESCRIPTION

PART NO.

EU2SYS-72

EU2SYS-72/P

EU2SYS-72/PR

EU2SYS-72/PL

1. BUSHING, STRAIN RELIEF	BU-3011	1	1	1	1
2. BUSHING, SNAP	BU-3378	1	1	1	1
3. CASTERS, PLATE	1002149	6	6	6	6
4. CORD, 6ft (1828mm)	CD-3607	1	1	1	1
5. FAN	FA-3568	1	1	1	1
6. FAN CORD	CD-33338	1	1	1	1
7. PANELS	1006857	4	4	4	4
8. TERMINAL BLOCK	BK-3023	2	2	2	2

EU2-96 SERIES

PART DESCRIPTION

PART NO.

EU2SYS-96

EU2SYS-96/PR

EU2SYS-96/PL

1. BUSHING, STRAIN RELIEF	BU-3011	1	1	1
2. BUSHING, SNAP	BU-3378	1	1	1
3. CASTERS, PLATE	1002149	6	6	6
4. CORD, 6ft (1828mm)	CD-3607	1	1	1
5. FAN	FA-3568	1	1	1
6. FAN CORD	CD-33338	1	1	1
7. PANELS	1006857	4	4	4
8. TERMINAL BLOCK	BK-3023	2	2	2

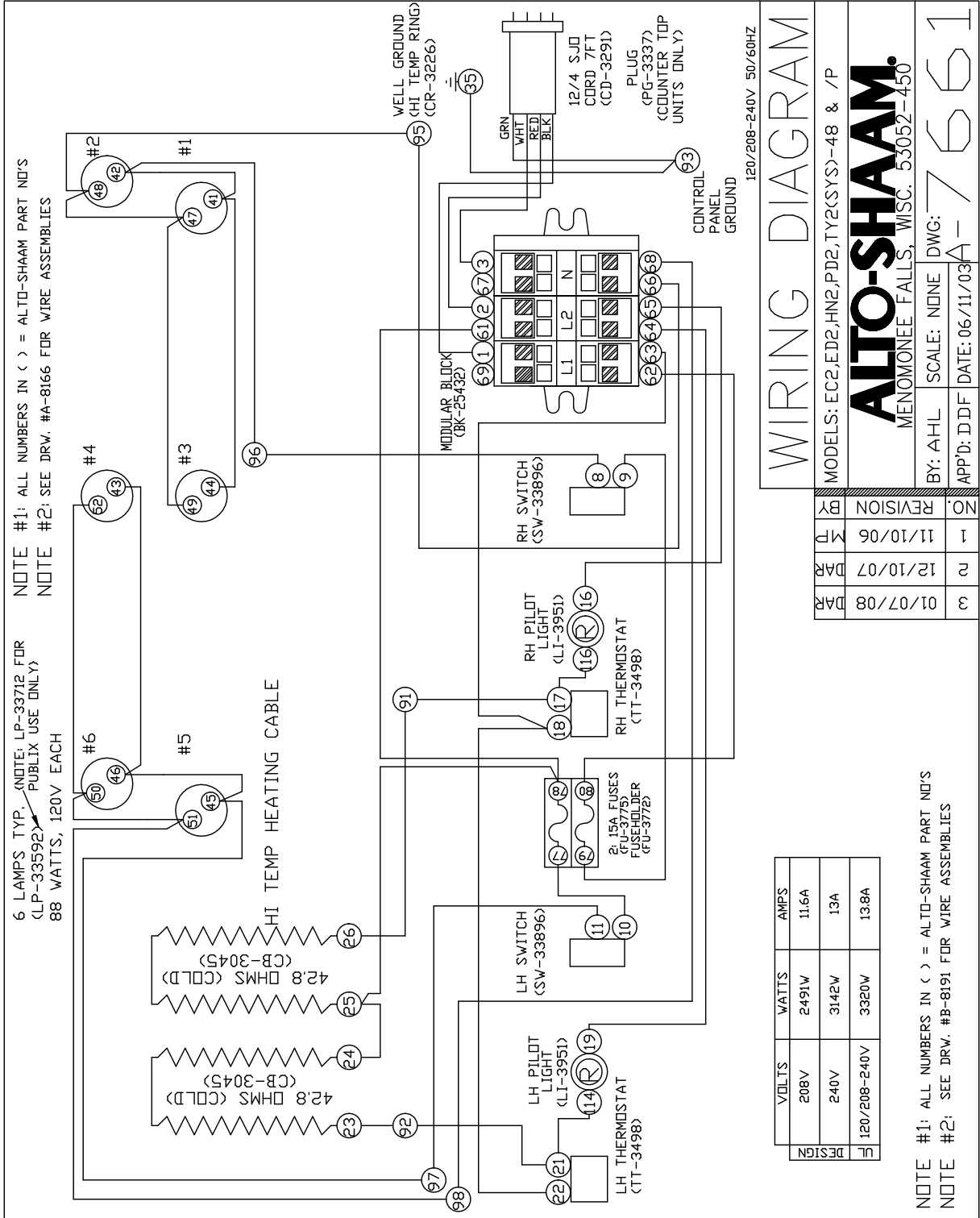

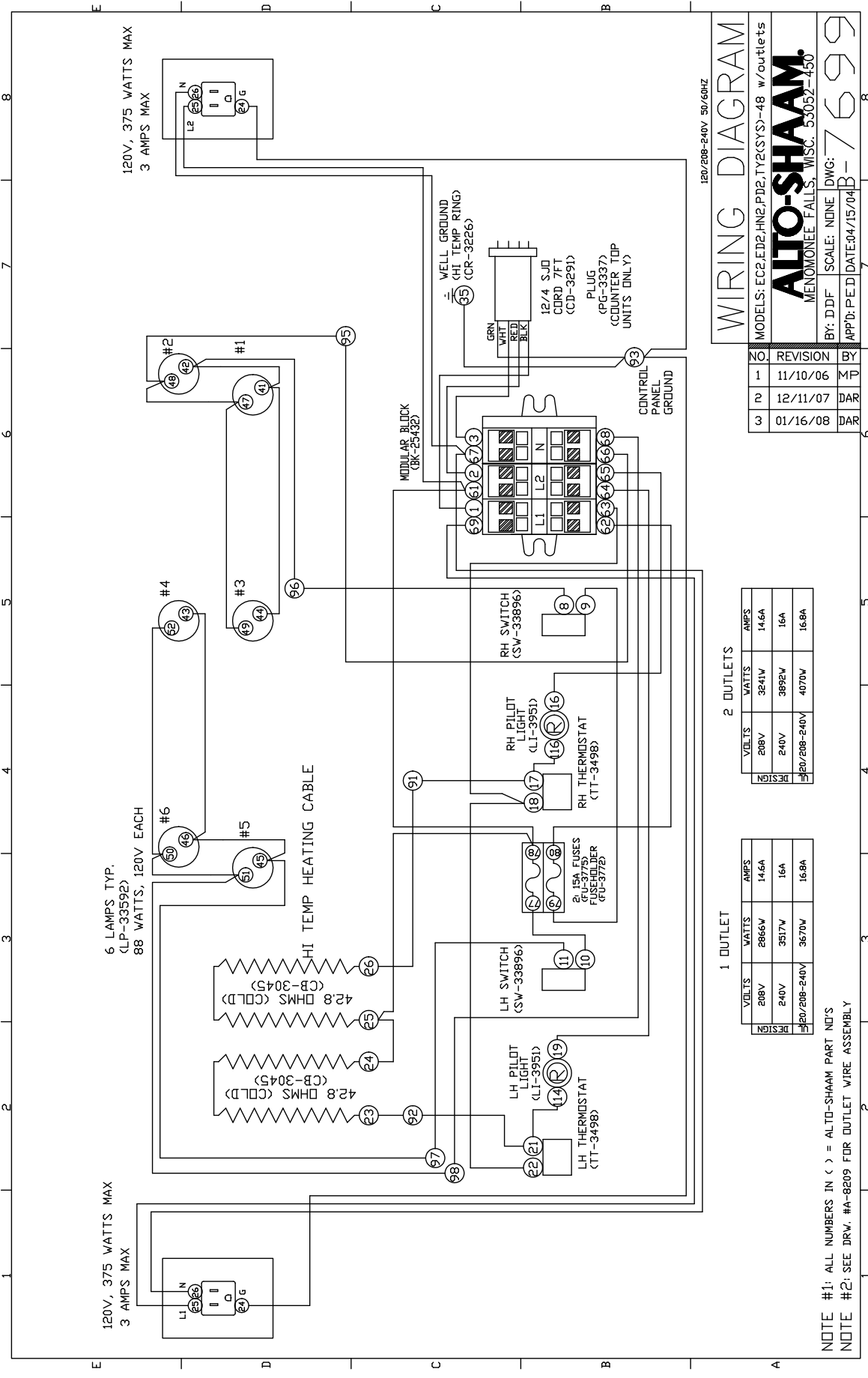

WIRING DIAGRAM

120/208-240V 50/60HZ

MODELS: EC2, ED2, HNE2, PD2, TY2(SYS)-48 w/outlets

ALTO-SHAAM
MENOMONEE FALLS, WISC. 53052-450

BY: D.D.F. SCALE: NONE DWG: 7699

APP'D: P.E.D DATE: 04/15/04

NO	REVISION	BY
1	11/10/06	MD
2	12/11/07	DAR
3	01/16/08	DAR

2 OUTLETS

VOLTS	WATTS	AMPS
208V	324W	14.6A
240V	369W	16A
208/208-240V	4070W	16.8A

1 OUTLET

VOLTS	WATTS	AMPS
208V	2865W	14.6A
240V	3517W	16A
208/208-240V	3670W	16.8A

NOTE #1: ALL NUMBERS IN () = ALTO-SHAAM PART NO'S

NOTE #2: SEE DRV. #A-8209 FOR OUTLET WIRE ASSEMBLY

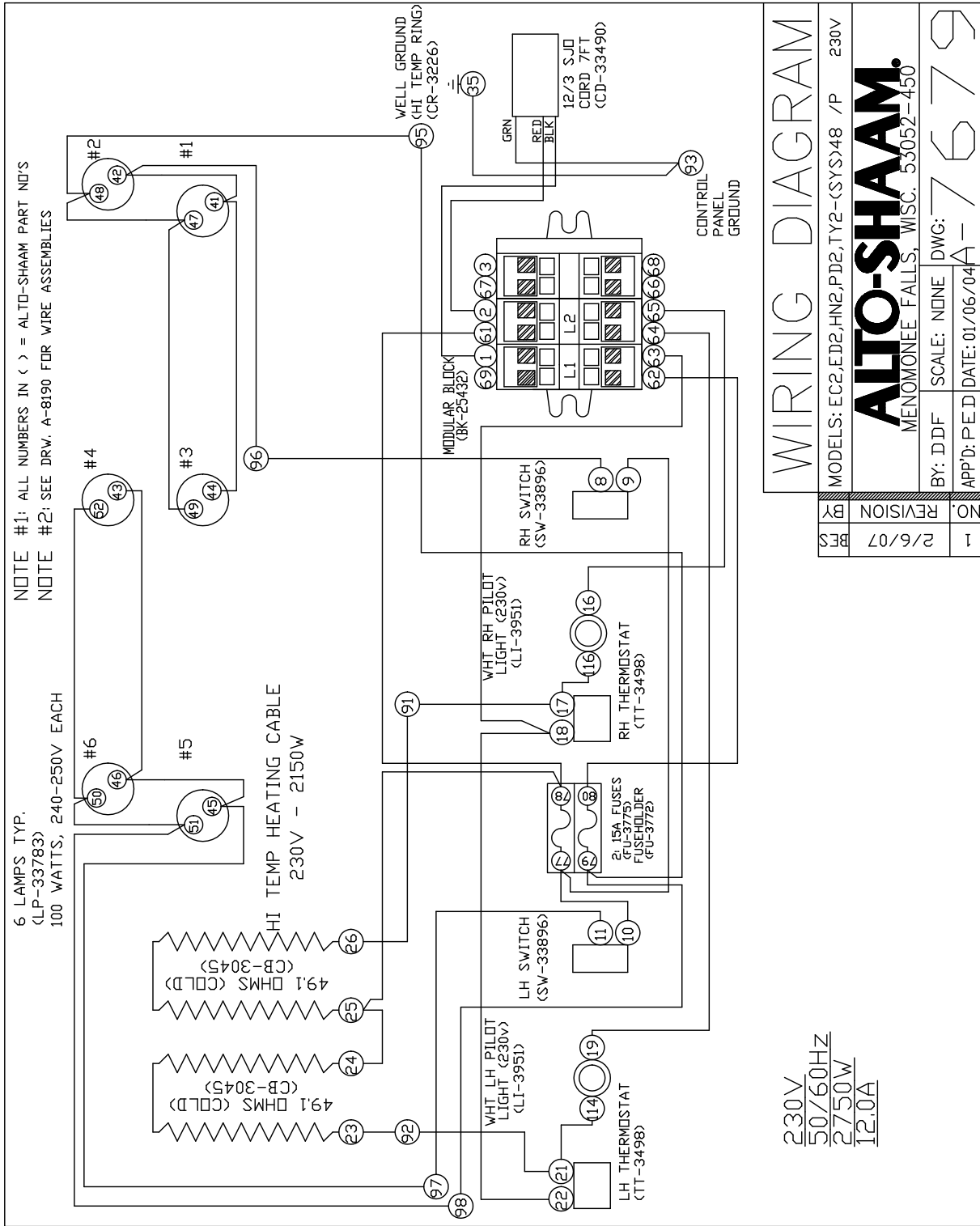

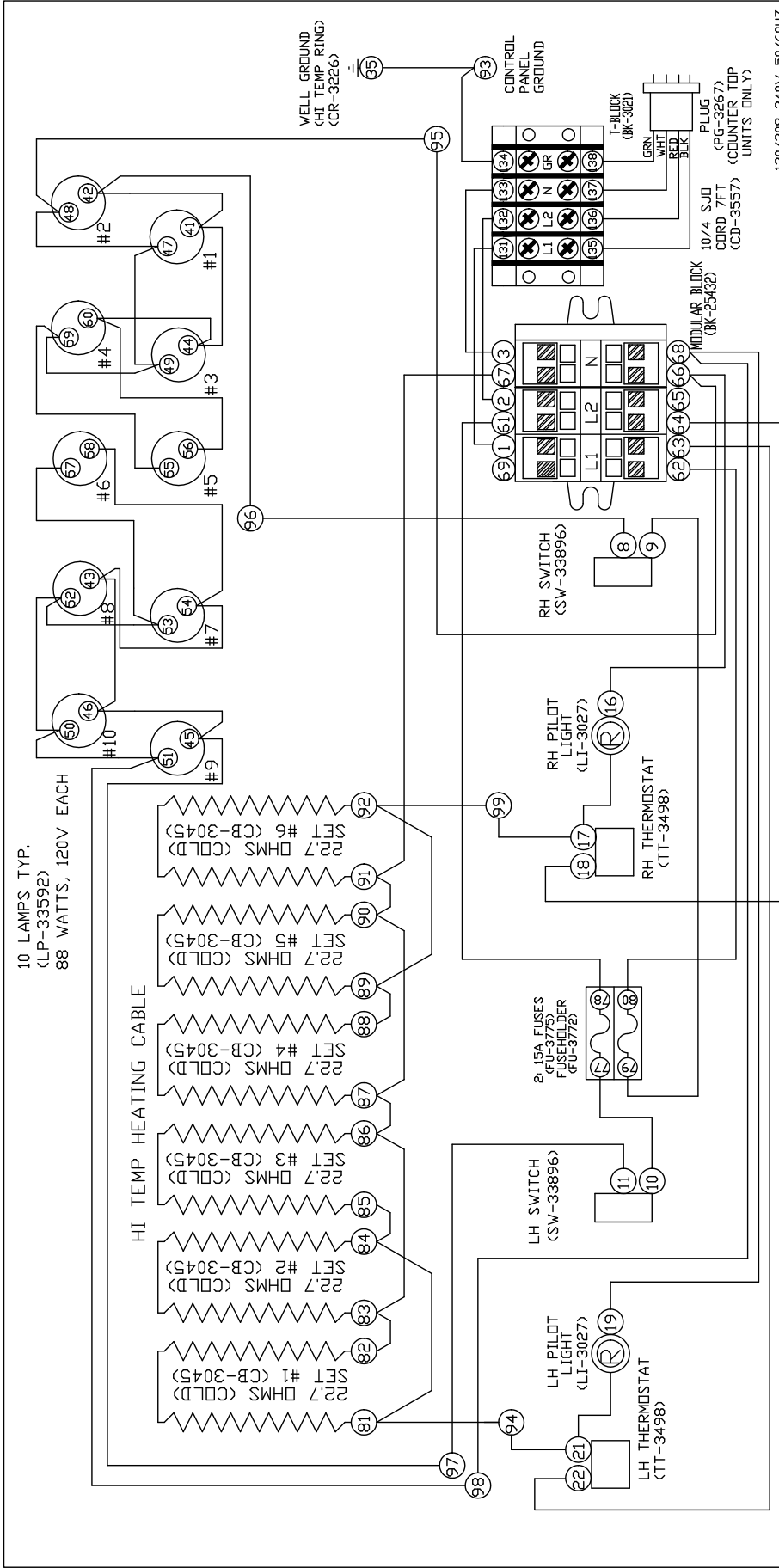

120/208-240V 50/60HZ

WIRING DIAGRAM

MODELS: EC2, ED2, HN2, PD2, TY2-72(SYS), P, PL, PR

ALTO-SHAAM
MENOMONEE FALLS, WISC. 53052-450

BY: P.E.D. SCALE: NONE DWG: 7680

APP'D: D.A.R. DATE: 01/07/04

DESIGN	VOLTS	WATTS	AMPS
1	120/208-240V	4580W	19A
2	120/208-240V	4500W	18.75A

NO.	REVISION	BY
1	02/26/04	NW
2	01/17/08	DAR

NOTE #1: ALL NUMBERS IN () = ALTO-SHAAM PART NO'S
NOTE #2: SEE DRW. #B-8191 FOR WIRE ASSEMBLIES

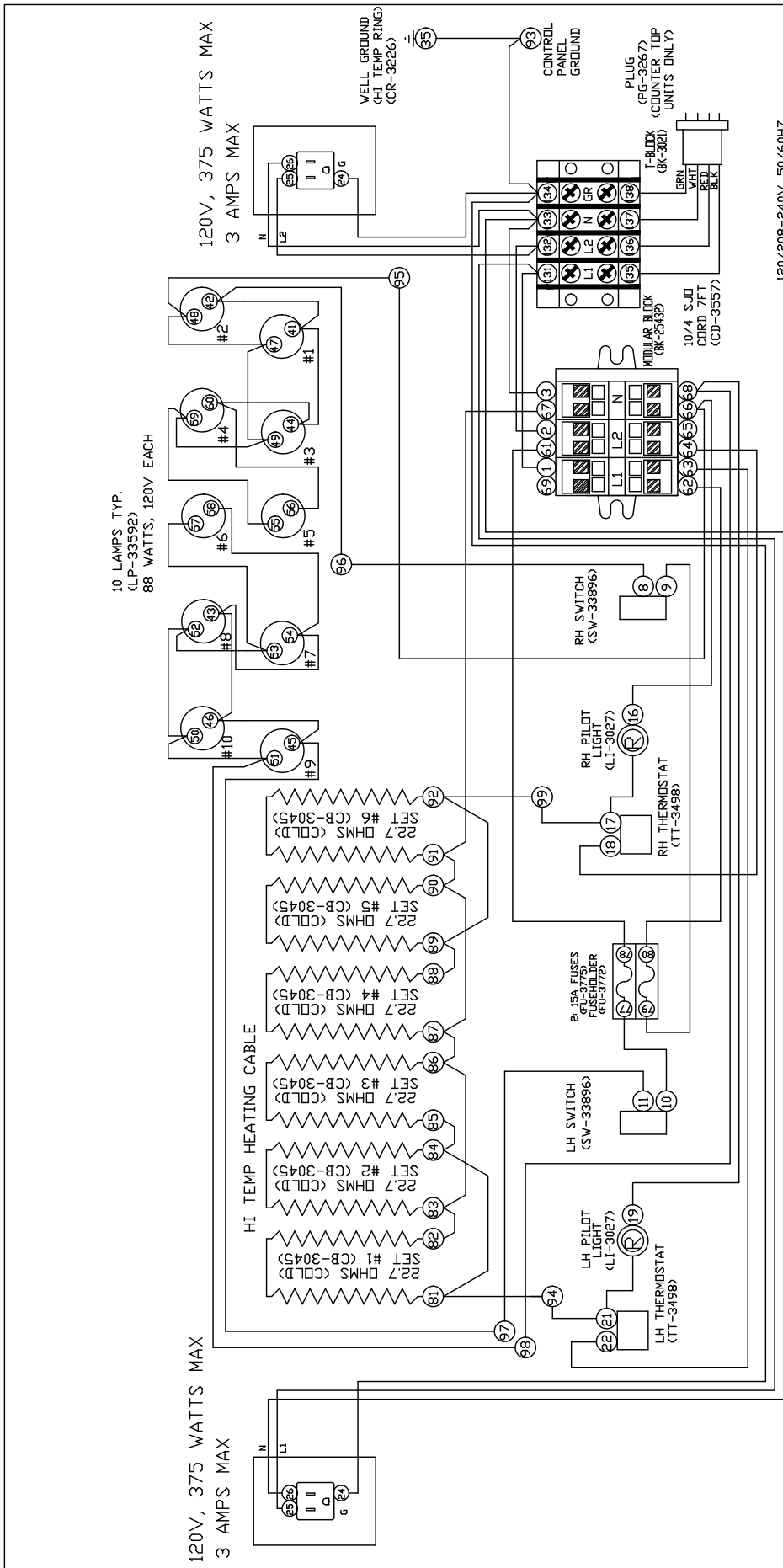

WIRING DIAGRAM

120/208-240V 50/60HZ

MODELS: EC2, ED2, HN2, PD2, TY2(SYS)-72 w/outlets

ALTO-SHAAM
MENOMONEE FALLS, WISC. 53052-450

BY: DDF SCALE: NONE DWG: 7700
APP'D: P.E.D DATE: 04/15/04

NO.	REVISION
1	01/17/08

2 OUTLETS

VOLTS	WATTS	AMPS
120/208-240V	5330W	22A
120/208-240V	5250W	23A

1 OUTLET

VOLTS	WATTS	AMPS
120/208-240V	4955W	22A
120/208-240V	4875W	22A

NOTE #1: ALL NUMBERS IN () = ALTO-SHAAM PART NOS
NOTE #2: SEE DRW. #A-8209 FOR OUTLET WIRE ASSEMBLY

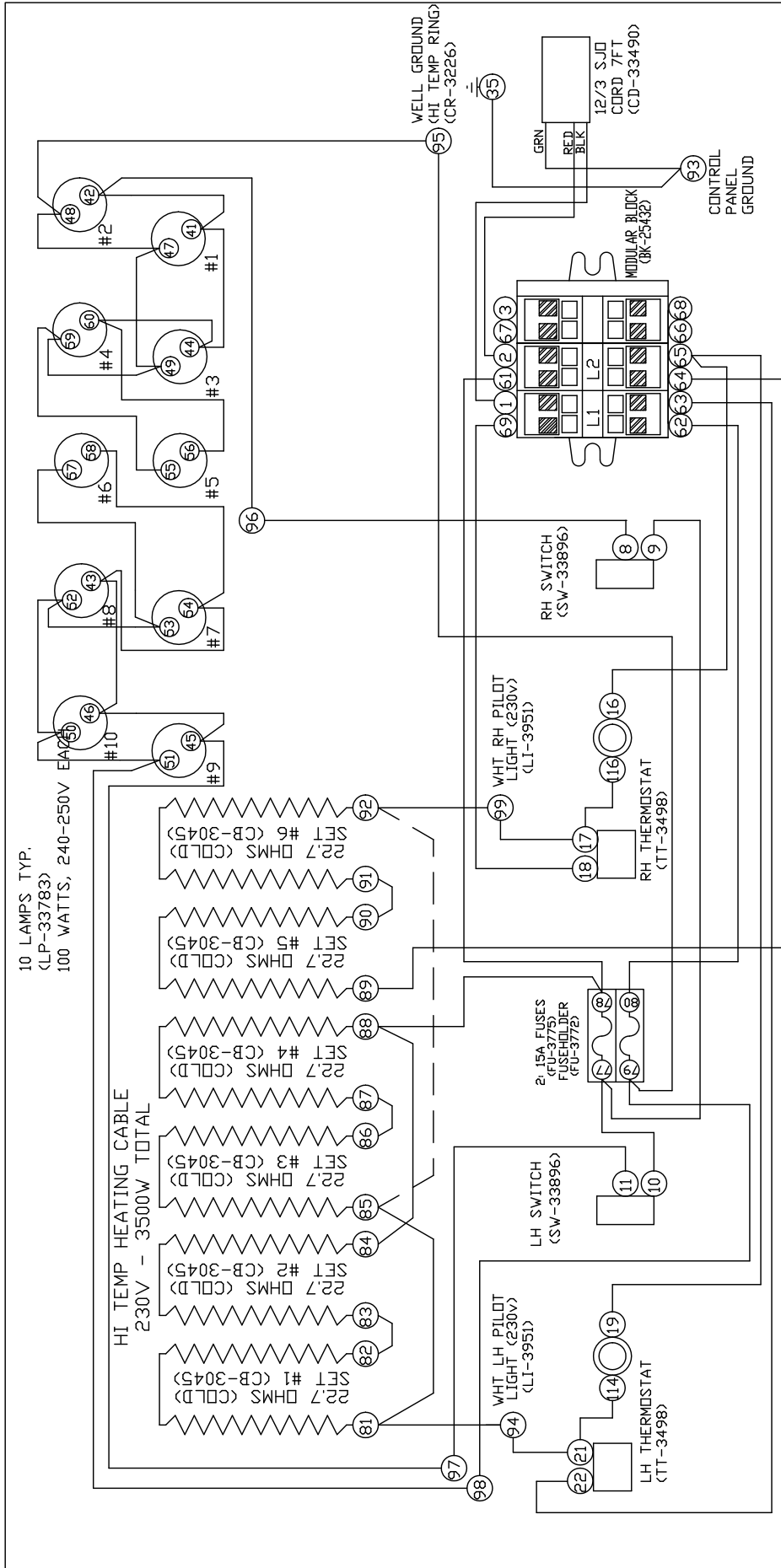

WIRING DIAGRAM

MODELS: EC2, ED2, HN2, PD2, TY2 (SYS) 230V

ALTO-SHAAM
MENOMONEE FALLS, WISC. 53052-450

BY: D.D.F. SCALE: NONE DWG: 7681
APP'D: P.E.D. DATE: 01/07/04

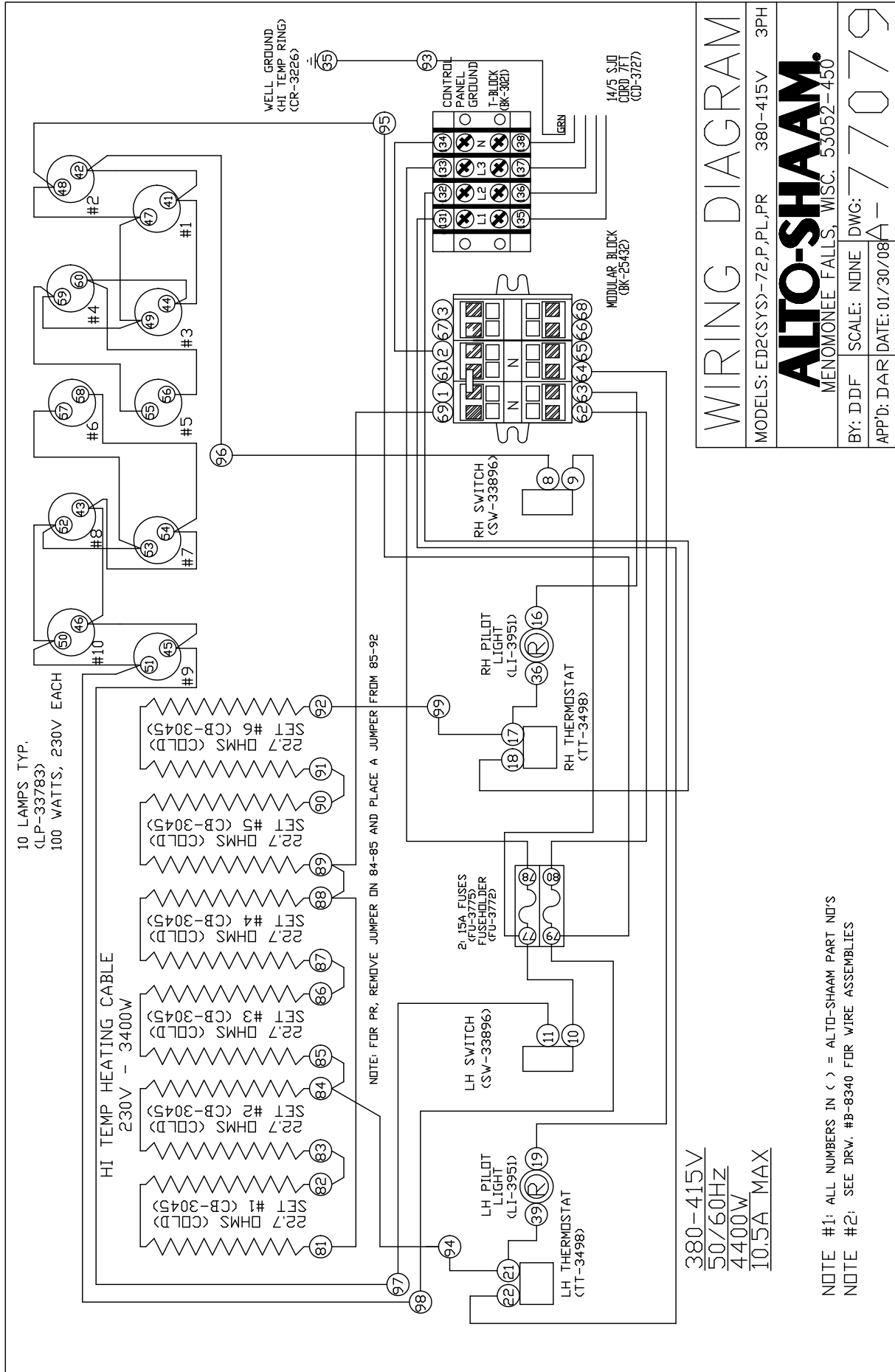

WIRING DIAGRAM

MODELS: ED2(SYS)-72,P,PL,PR 380-415V 3PH

ALTO-SHAAM
MENOMONEE FALLS, WISC. 53052-450

BY: DDF SCALE: NONE DWG: 77079
APP'D: DAR DATE: 01/30/08 A-77079

NOTE #1: ALL NUMBERS IN () = ALTO-SHAAM PART NO'S
NOTE #2: SEE DRW. #B-8340 FOR WIRE ASSEMBLIES

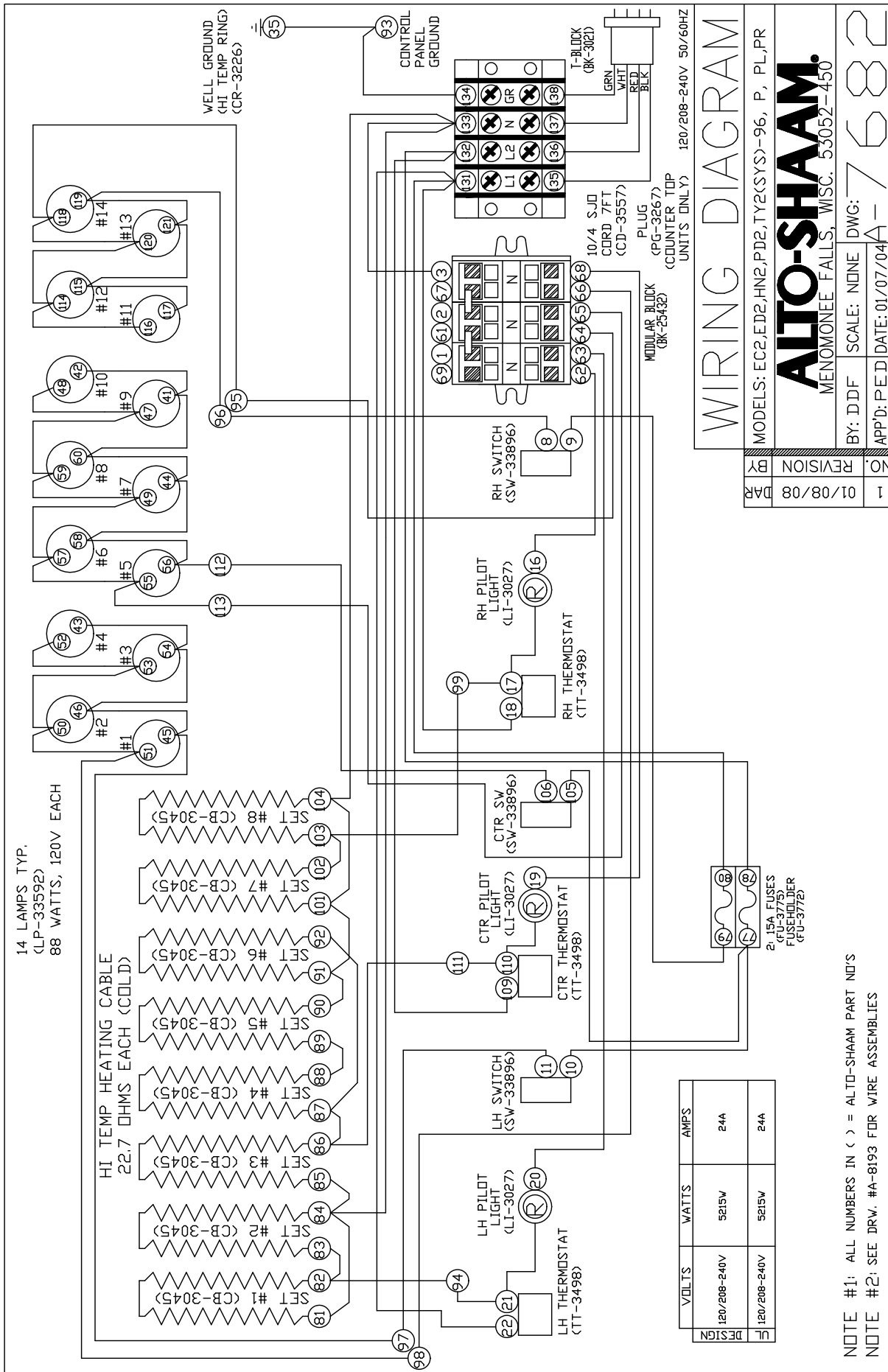

WIRING DIAGRAM

MODELS: EC2, ED2, HN2, PD2, TY2 (SYS)-96, P, PL, PR

ALTO-SHAAM
MEMONONEE FALLS, WISC. 53052-450

BY: DDF SCALE: NONE DWG: 7682

APP'D: P.E.D. DATE: 01/07/04

NO	REVISION	BY
1	01/08/08	1

VOLTS	WATTS	AMPS
120/208-240V	5215W	24A
120/208-240V	5215W	24A

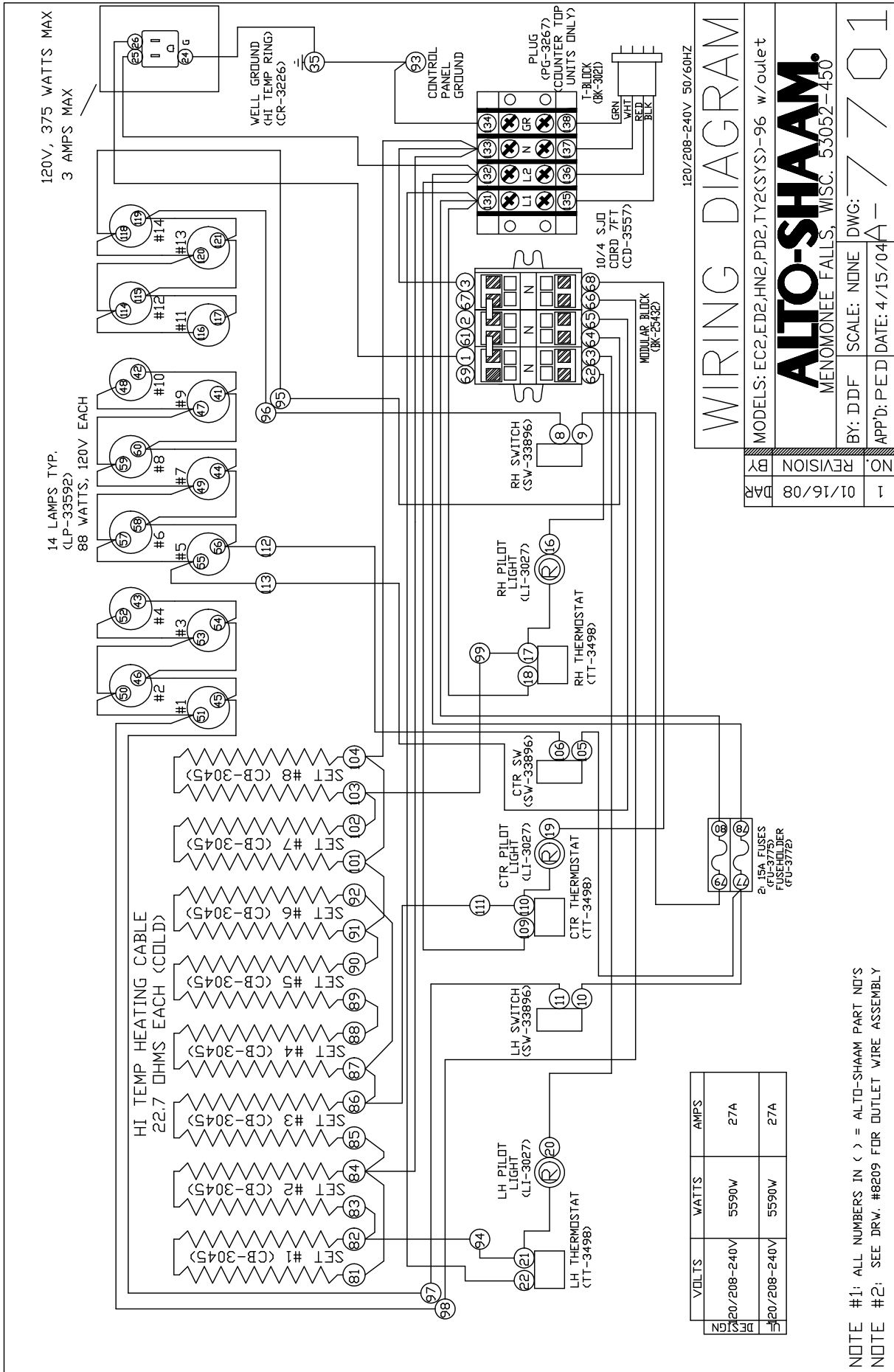

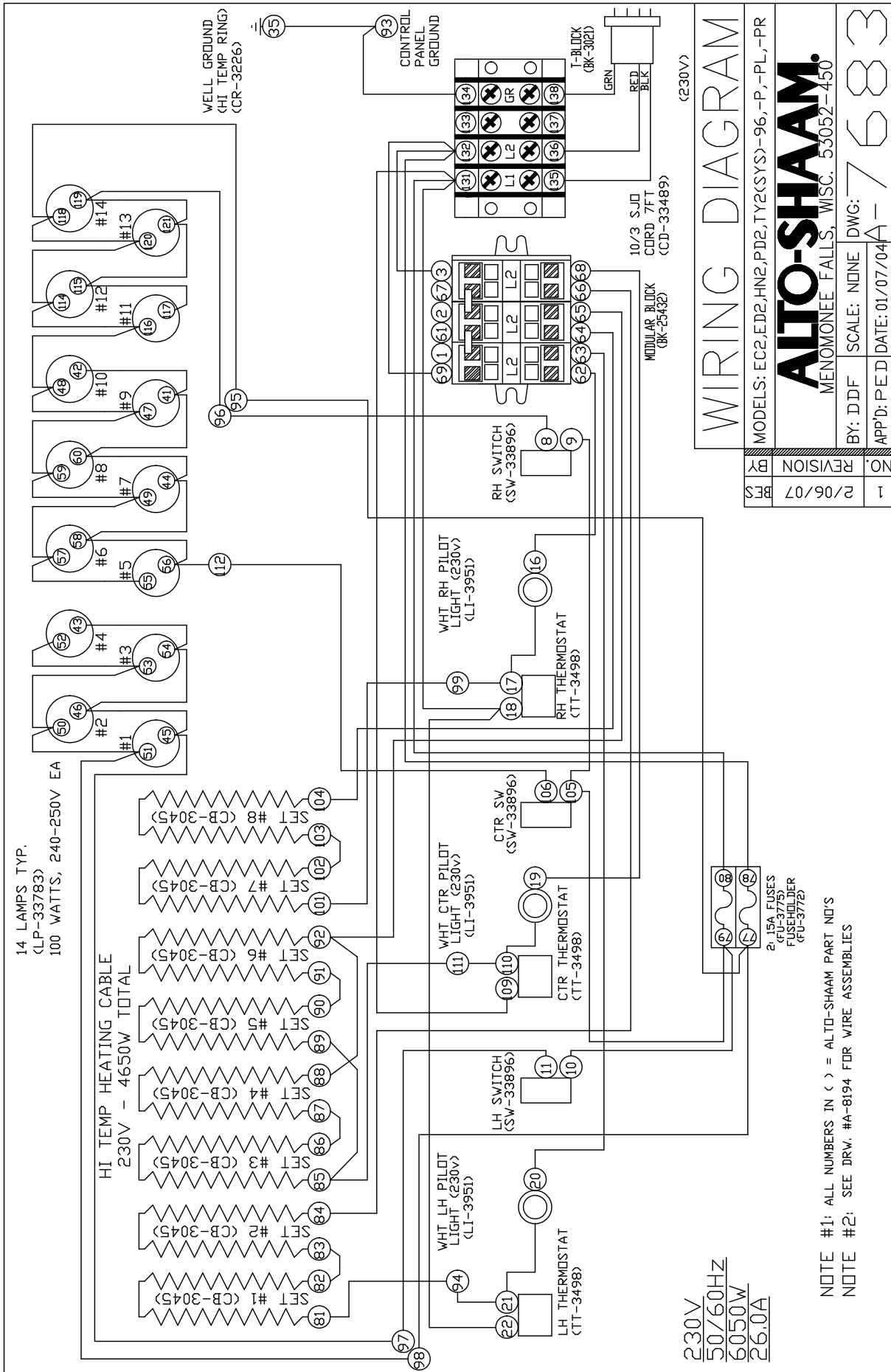

WIRING DIAGRAM

MODELS: EC2, ED2, HN2, PD2, TY2(SYS)-96,-P,-PL,-PR

ALTO-SHAAM.
MENOMONEE FALLS, WISC. 53052-450

NO	REVISION	BY	SCALE	DWG:	7683
1	2/06/07	BES	NONE	APP'D: P.E.D	DATE: 01/07/04

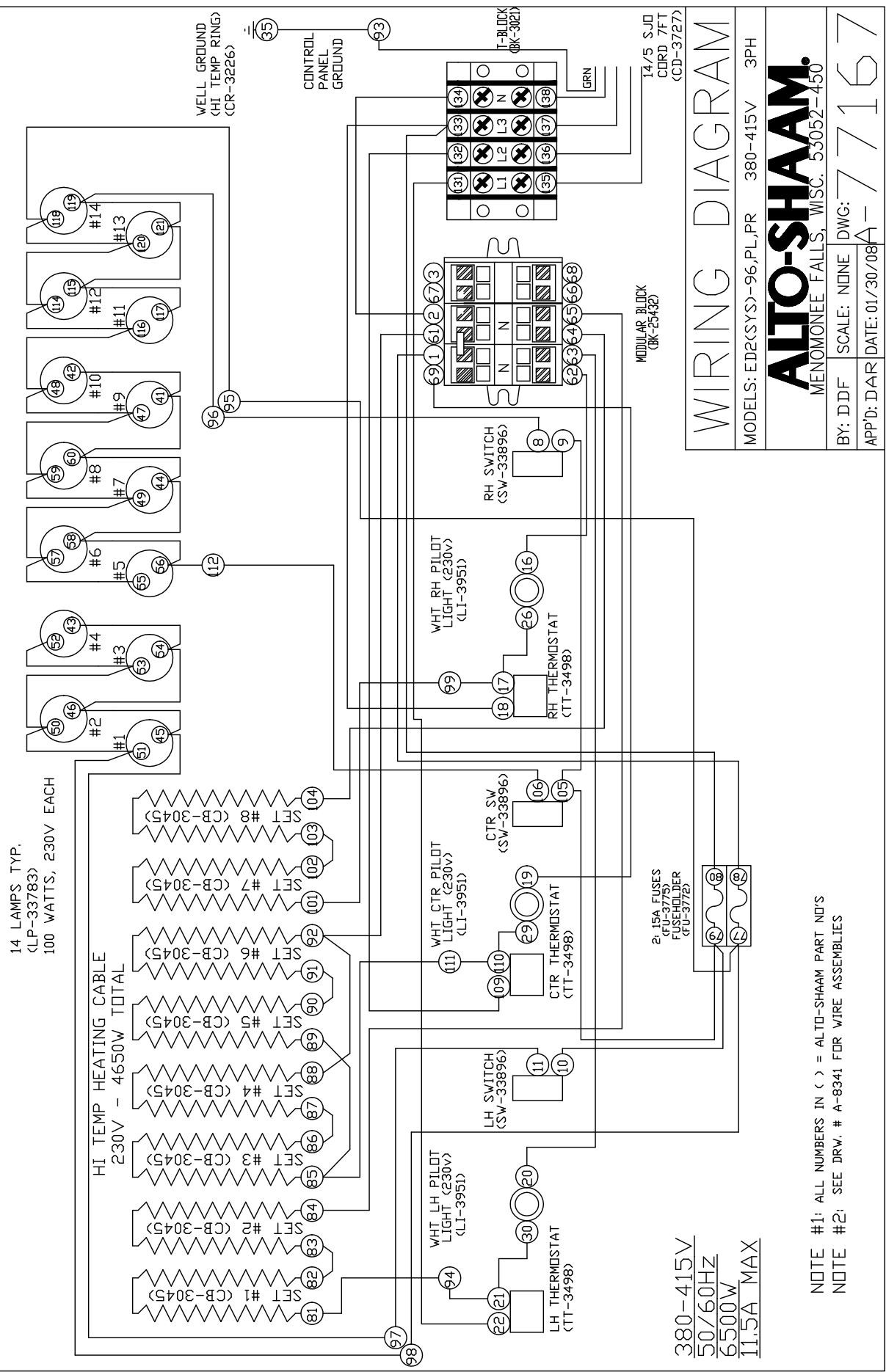

WIRING DIAGRAM

MODELS: ED2(SYS)-96,PL,PR 380-415V 3PH

ALTO-SHAAM
MENOMONEE FALLS, WISC. 53052-450

BY: DDF SCALE: NONE DWG: 77167
APP'D: DAR DATE: 01/30/08 A-77167

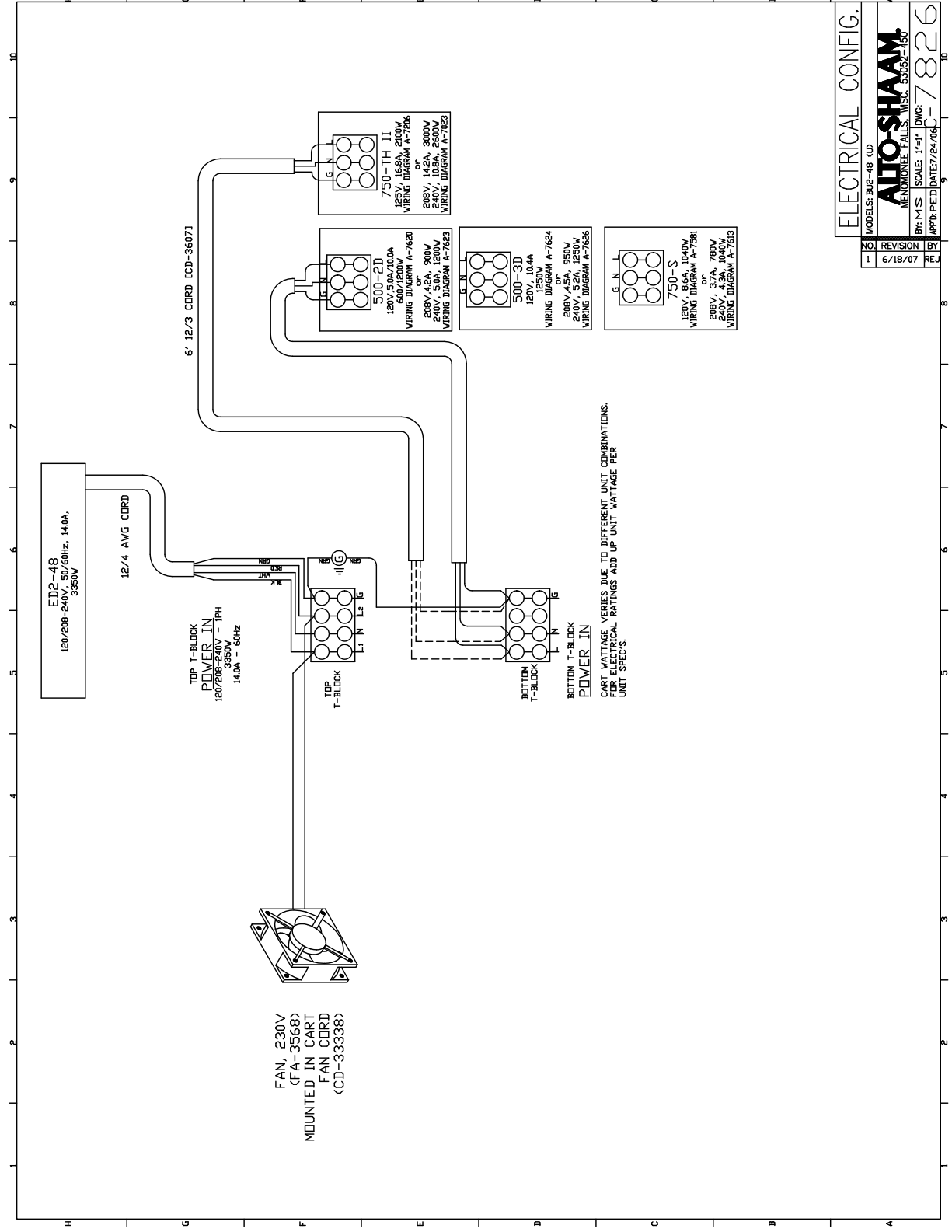

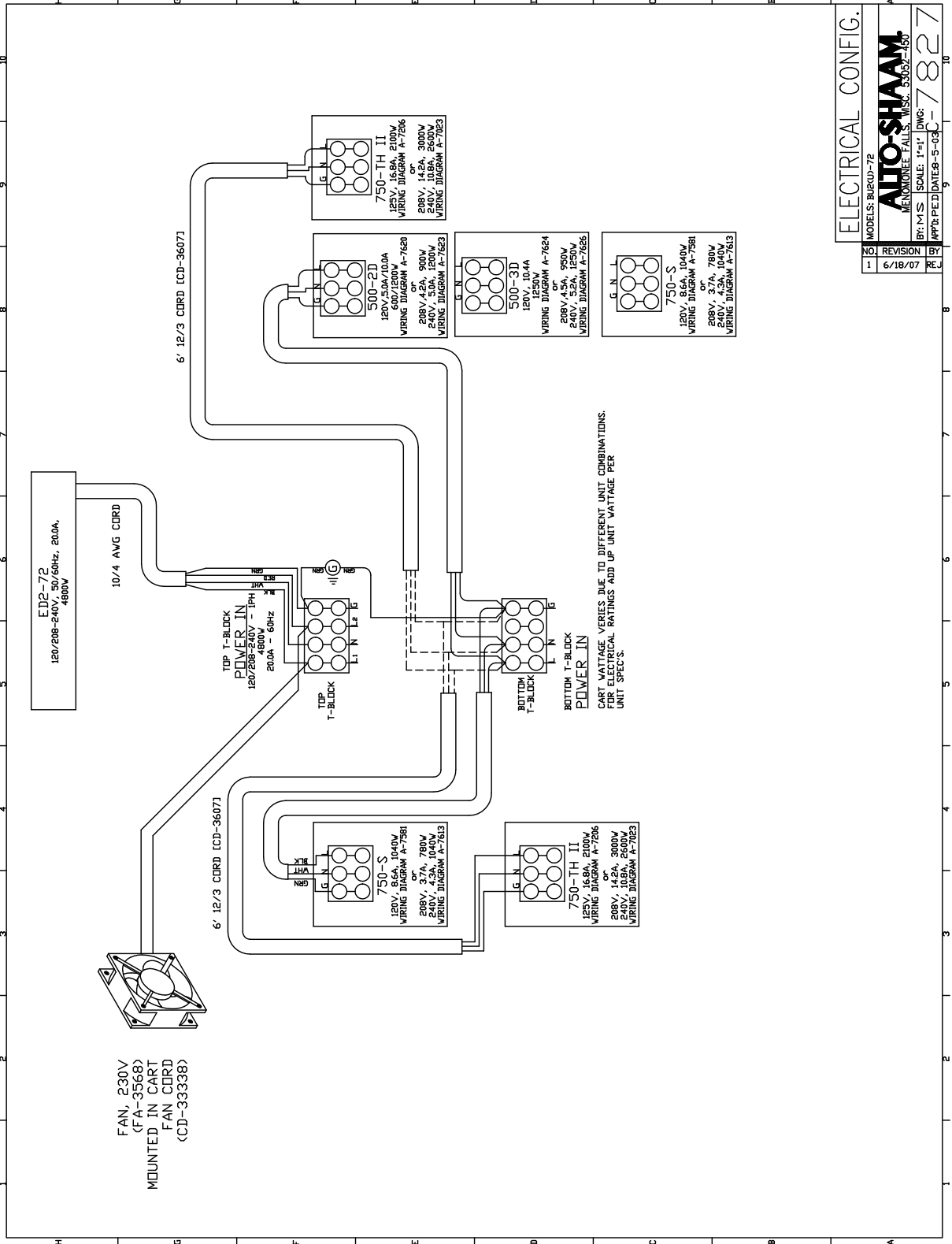

ELECTRICAL CONFIG.

NO	REVISION	BY
1	6/18/07	REL

MODELS: BURUD-72
ALTO SHAM
 MEMPHIS FALLS, MISS. 39052-450
 BY: M/S SCALE: 1"=1'
 APPR: PED DATE: 6-5-08 DWG: 7827

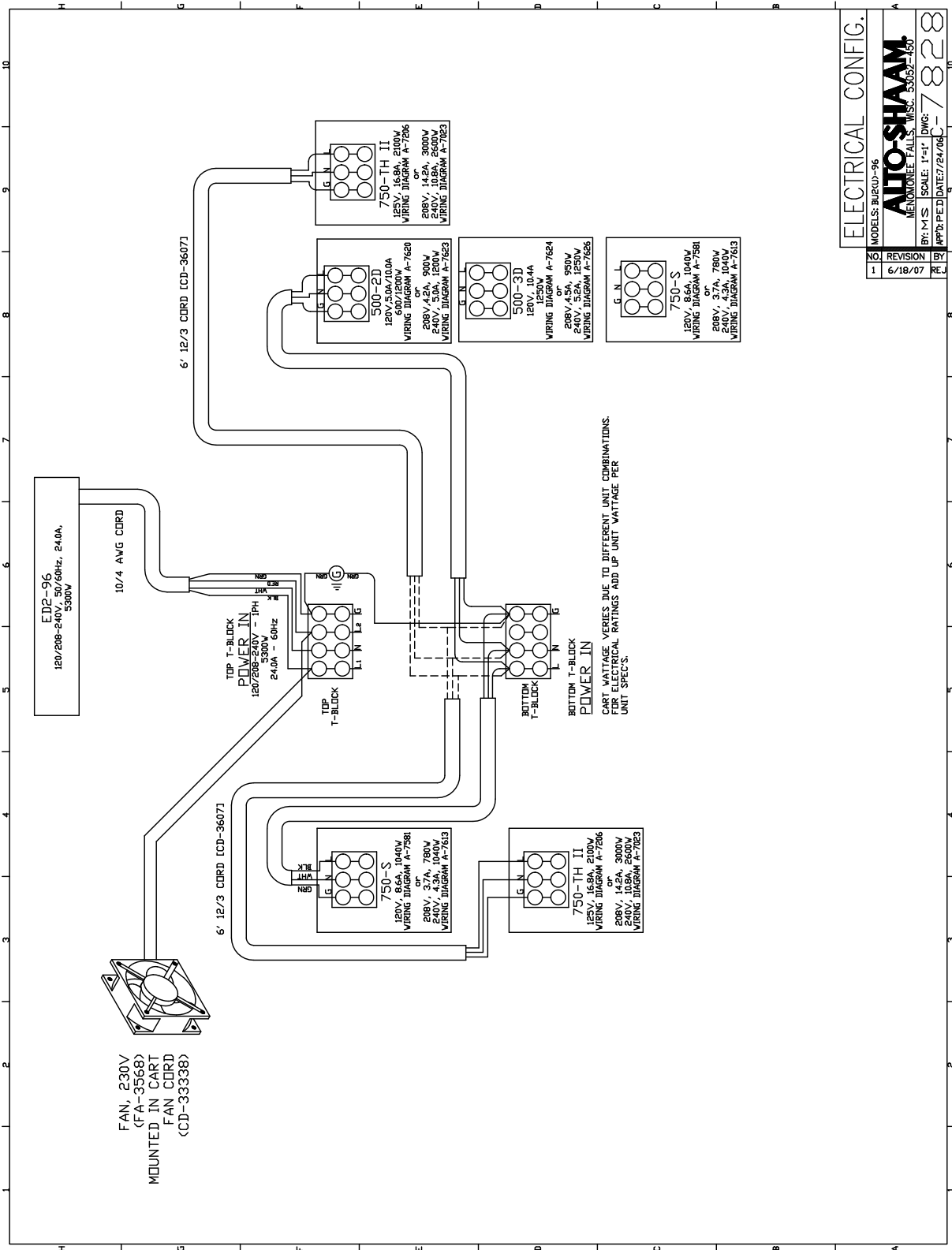

ELECTRICAL CONFIG.

1	REVISION	BY	DATE
1	6/18/07	M.S.	7/24/08

MODELS: BUKU-96
ALTO-SHAM
 MENOMONEE FALLS, WISC. 53052-4500
 SCALE: 1"=1' DWG: 7828
 APP'D: P.E.D. DATE: 7/24/08

TRANSPORTATION DAMAGE and CLAIMS

ALTO SHAAM LIMITED WARRANTY



All Alto-Shaam equipment is sold F.O.B. shipping point, and when accepted by the carrier, such shipments become the property of the consignee.

Should damage occur in shipment, it is a matter between the carrier and the consignee. In such cases, the carrier is assumed to be responsible for the safe delivery of the merchandise, unless negligence can be established on the part of the shipper.

1. Make an immediate inspection while the equipment is still in the truck or immediately after it is moved to the receiving area. Do not wait until after the material is moved to a storage area.
2. Do not sign a delivery receipt or a freight bill until you have made a proper count and inspection of all merchandise received.
3. Note all damage to packages directly on the carrier's delivery receipt.
4. Make certain the driver signs this receipt. If he refuses to sign, make a notation of this refusal on the receipt.
5. If the driver refuses to allow inspection, write the following on the delivery receipt:
Driver refuses to allow inspection of containers for visible damage.
6. Telephone the carrier's office immediately upon finding damage, and request an inspection. Mail a written confirmation of the time, date, and the person called.
7. Save any packages and packing material for further inspection by the carrier.
8. Promptly file a written claim with the carrier and attach copies of all supporting paperwork.

We will continue our policy of assisting our customers in collecting claims which have been properly filed and actively pursued. We cannot, however, file any damage claims for you, assume the responsibility of any claims, or accept deductions in payment for such claims.

Alto-Shaam, Inc. warrants to the original purchaser that any original part that is found to be defective in material or workmanship will, at Alto-Shaam's option, subject to provisions hereinafter stated, be replaced with a new or rebuilt part.

The labor warranty remains in effect one (1) year from installation or fifteen (15) months from the shipping date, whichever occurs first. Alto-Shaam will bear normal labor charges performed during standard business hours, and excluding overtime, holiday rates or any additional fees.

The parts warranty remains in effect for one (1) year from installation or fifteen (15) months from the shipping date, whichever occurs first.

However, the heating element on Halo Heat® cook/hold ovens and the refrigeration compressor on Alto-Shaam Quickchillers™ are warranted for a period of five (5) years from installation. The labor warranty is the same as stated above; namely, for one (1) year from installation or fifteen (15) months from the shipping date, whichever occurs first.

THIS WARRANTY DOES NOT APPLY TO:

1. Calibration.
2. Replacement of light bulbs and/or the replacement of display case glass due to damage of any kind.
3. Equipment damage caused by accident, shipping, improper installation or alteration.
4. Equipment used under conditions of abuse, misuse, carelessness or abnormal conditions including, but not limited to, equipment subjected to harsh or inappropriate chemicals including, but not limited to, compounds containing chloride or quaternary salts, poor water quality, or equipment with missing or altered serial numbers.
5. Damage incurred as a direct result of poor water quality, inadequate maintenance of steam generators and/or surfaces affected by water quality. Water quality and required maintenance of steam generating equipment is the responsibility of the owner/operator.
6. Damage caused by use of any cleaning agent other than Alto-Shaam's Combitherm® Cleaner including, but not limited to, damage due to chlorine or other harmful chemicals. Use of Alto-Shaam's Combitherm® Cleaner on Combitherm® ovens is highly recommended.
7. Any losses or damage resulting from malfunction, including loss of product or consequential or incidental damages of any kind.
8. Equipment modified in any manner from original model, substitution of parts other than factory authorized parts, removal of any parts including legs, or addition of any parts.

This warranty is exclusive and is in lieu of all other warranties, expressed or implied, including the implied warranties of merchantability and fitness for a particular purpose. In no event shall Alto-Shaam be liable for loss of use, loss of revenue or profit, or loss of product, or for any indirect or consequential damages. No person except an officer of Alto-Shaam, Inc. is authorized to modify this warranty or to incur on behalf of Alto-Shaam any other obligation or liability in connection with Alto-Shaam equipment.

ALTO-SHAAM, INC.

RECORD THE MODEL AND SERIAL NUMBER OF THE APPLIANCE FOR EASY REFERENCE.
ALWAYS REFER TO BOTH MODEL AND SERIAL NUMBER IN ANY CONTACT WITH ALTO-SHAAM REGARDING THIS APPLIANCE.

Model: _____ Date Installed: _____
Voltage: _____ Purchased From: _____
Serial Number: _____

W164 N9221 Water Street • P.O. Box 450 • Menomonee Falls, Wisconsin 53052-0450 • U.S.A.
PHONE: 262.251.3800 • 800.558-8744 USA/CANADA FAX: 262.251.7067 • 800.329.8744 U.S.A. ONLY

www.alto-shaam.com

PRINTED IN U.S.A.